

TECHNICAL MANUAL  
OPERATOR'S AND AVIATION UNIT  
MAINTENANCE MANUAL  
INCLUDING REPAIR PARTS AND  
SPECIAL TOOLS LIST  
FOR  
HELMET, FLYER'S: SPH-4B  
(NSN 8415-01-308-5359) (REGULAR)  
(NSN 8415-01-308-5360) (EXTRA LARGE)

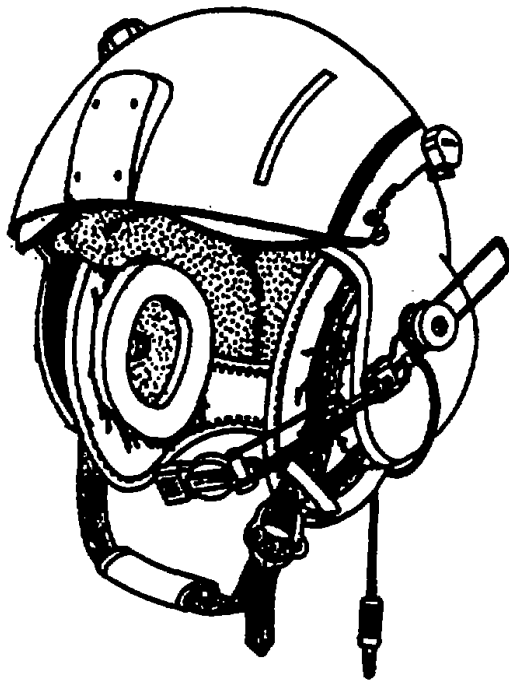

DISTRIBUTION STATEMENT A: Approved for public release; distribution is unlimited.

---

HEADQUARTERS, DEPARTMENT OF THE ARMY  
15 JANUARY 1993

CHANGE  
NO. 2

HEADQUARTERS  
DEPARTMENT OF THE ARMY  
WASHINGTON, D.C., 30 JUNE 1994

OPERATOR'S AND AVIATION UNIT MAINTENANCE MANUAL  
INCLUDING REPAIR PARTS AND SPECIAL TOOLS LIST

FOR

HELMET, FLYER'S: SPH-4B

(NSN 8415-01-308-5359) (REGULAR)  
(NSN 8415-01-308-5360) (EXTRA LARGE)

DISTRIBUTION STATEMENT A: Approved for public release; distribution is unlimited.

TM 1-8415-215-12&P, 15 January 1993, is changed as follows:

1. Remove and insert pages as indicated below. New or changed text material is indicated by a vertical bar in the margin. An illustration change is indicated by a miniature pointing hand.

Remove pages

a and b

----

Insert pages

a and b

3-2.1 through 3-2.3/

(3-2.4 blank)

2. Retain this sheet in front of manual for reference purposes.

By Order of the Secretary of the Army:

Official:

MILON H. HAMILTON  
*Administrative Assistant to the  
Secretary of the Army*  
08991

GORDON R. SULLIVAN  
*General, United States Army  
Chief of Staff*

DISTRIBUTION:

To be distributed in accordance with DA Form 12-31-E, block no. 3317, requirements for TM 1-8415-215-12&P.

CHANGE  
NO. 1

HEADQUARTERS  
DEPARTMENT OF THE ARMY  
WASHINGTON, D.C., 30 December 1993

OPERATOR'S AND AVIATION UNIT  
MAINTENANCE MANUAL  
INCLUDING REPAIR PARTS AND  
SPECIAL TOOLS LIST

FOR

HELMET, FLYER'S: SPH-4B

(NSN 8415-01-308-5359) (REGULAR)  
(NSN 8415-01-308-5360) (EXTRA LARGE)

DISTRIBUTION STATEMENT A: Approved for public release; distribution is unlimited.

TM 1-8415-215-12&P, 15 January 1993, is changed as follows:

1. Remove and insert pages as indicated below. New or changed text material is indicated by a vertical bar in the margin. An illustration change is indicated by a miniature pointing hand.

Remove pages

Insert pages

-----  
A-1/(A-2 blank)

2-8.1/(2-8.2 blank)  
A-1/(A-2 blank)

2. Retain this sheet in front of manual for reference purposes.

By Order of the Secretary of the Army:

Official:

MILTON H. HAMILTON  
*Administrative Assistant to the  
Secretary of the Army*  
05986

GORDON R. SULLIVAN  
*General, United States Army  
Chief of Staff*

DISTRIBUTION:

To be distributed in accordance with DA Form 12-31-E, block no. 3317, requirements for TM 1-8415-215-12&P.

**WARNINGS**

When donning the helmet, ensure that nape strap is pulled down so that keeper tab is taut. Failure to do so will decrease helmet stability and may cause injury to the wearer.

The helmet must be worn with the chinstrap properly attached and adjusted. Failure to secure the chinstrap will decrease helmet stability and may cause injury to the wearer.

Chinstrap must be secured under crewmember's chin at all times. DO NOT allow oxygen mask to be placed between chinstrap and chin. Failure to heed this warning will result in a loss of stability and may cause injury to the crewmember.

**WARNINGS**

Prior to entering potentially hazardous situations, the chin and nape straps should be secured very tightly. Failure of personnel to comply with this procedure can result in their injury.

**WARNINGS**

Rubber base adhesive and silicone rubber base adhesive are extremely flammable. Do not use when smoking or in the vicinity of an open flame.

**WARNINGS**

Paint could be flammable, toxic in sufficient concentrations, and it could cause dermatitis with skin contact. Care should be taken to avoid breathing of the vapors and skin contact. Avoid use while smoking or in the vicinity of open flames.

**WARNINGS**

Headaches can result if the cross straps are too tight. If they are too loose, hearing protection can be affected.

**WARNINGS**

Due to the serious limitations imposed by the Laser Protective Visors (LPVs) on visual acuity outside of the aircraft as well as on flight displays within the cockpit, the LPVs will only be used when actual laser hazards exist. For day or night VFR flights at altitudes below low level flight, the pilot and co-pilot will analyze the current situation and both will decide if flight should be continued with the LPVs in use. Some considerations are the local laser hazards, ambient light levels, and terrain. Approval for use must be annotated on the flights crews mission brief.

**WARNINGS**

Two LPVs cannot be worn in the down position at the same time.

**WARNINGS**

The dark LPVs (AMBER) are not compatible with aircraft or ground support night lighting and are not safe for twilight or night flight.

Do not use the dark LPVs during twilight or at night.

**WARNINGS**

The dark LPVs (AMBER) will change the appearance of and possibly eliminate some red and/or green light sources. Testing indicates that some red lights take on an orange hue, that some cockpit warning lights are difficult to read though still visible, and that some cockpit gauges are illegible.

Do not use the dark LPVs for IFR flight.

**WARNINGS**

The light LPVs (GREEN) will change the appearance of any possibly eliminate some red light sources. Testing indicates that some red lights take on an orange hue, that some cockpit warning lights are difficult to read though still visible, that the distance one can see some exterior red lights is reduced, and that red cockpit map lights are virtually unusable.

Use extra caution at night.

**WARNINGS**

The LPVs are laser wavelength specific and will protect against only those lasers of the designated wavelength. The light LPV (GREEN) will protect against ruby and neodymium lasers only. The dark LPV (AMBER) will protect against ruby, neodymium, and one other (classified wavelength) lasers only.

**WARNINGS**

If lased, do not stare at the laser source. Some lasers have secondary harmonic wavelengths that may cause some eye damage - these secondary wavelengths may not be filtered by these LPVs.

**WARNINGS**

The LPVs are not intended to provide protection against broad spectrum bright light. Do not use the LPVs to view solar eclipses, electric welding or other potentially eye damaging light sources.

**WARNINGS**

The LPVs are not to be used as a substitute for other types of laser eye protection. Protection during maintenance or servicing of specific laser systems should be as specified by the appropriate technical manual.

**WARNINGS**

The LPVs reduce ambient light levels available to the eye. Eye Accommodation should be allowed prior to operation during periods of dusk or dawn.

**CAUTION**

Excessive scratching may degrade the laser protection factor of the LPVs. Clean according to instructions. Turn in LPVs with an excessive number of scratches or any deep scratches.

**CAUTION**

Exposure to direct sunlight may degrade the laser protection factor of the LPVs. Unnecessary sunlight exposure should be avoided.

**CAUTIONS**

When donning or doffing the helmet, spread the helmet only enough to clear head. Excessive spreading can damage the helmet.

When unsoldering the leads for the AH-1S sight, be careful not to break the glass on the magnetic switch.

## NOTES

For aircrews operating flying gunships, the AH-1S boresight must be adjusted by the gunner after the initial fitting and every 120 days thereafter (during preventive maintenance).

If an M-43 mask is to be used with the helmet. Rub a small amount of talcum powder over the surface of the hood to make donning the helmet with the thermoplastic liner easier.

The cloth cover of the thermoplastic liner can be removed and laundered or dry-cleaned. After each cleaning, replacement of the two-sided tape is recommended.

If a wedge shaped washer exists on the bottom of an AH-1 S sight to be installed, this washer must be removed and attached with the flat spacer provided.

TECHNICAL MANUAL

NO. 1-8415-215-12&P

HEADQUARTERS  
DEPARTMENT OF THE ARMY  
WASHINGTON, D.C., 15 JANUARY 1993

**OPERATOR'S AND AVIATION UNIT MAINTENANCE MANUAL  
INCLUDING REPAIR PARTS AND SPECIAL TOOLS LIST**

FOR

**HELMET, FLYER'S: SPH-4B**

**(NSN 8415-01-308-5359) (REGULAR)  
(NSN 8415-01-308-5360) (EXTRA LARGE)**

**REPORTING ERRORS AND RECOMMENDING IMPROVEMENTS**

You can help improve this manual. If you find any mistakes or if you know of any way to improve the procedures, please let us know. Mail your letter, DA Form 2028 (Recommended Changes to Publications and Blank Forms), or DA Form 2028-2 located in the back of this manual direct to: Commander, US Army Aviation and Troop Command, ATTN: AMSAT-1-MP, 4300 Goodfellow Blvd., St. Louis, MO 63120-1798. A reply will be furnished directly to you.

**DISTRIBUTION STATEMENT A: Approved for public release; distribution is unlimited.**

**TABLE OF CONTENTS**

		<u>Page</u>
CHAPTER 1	INTRODUCTION AND GENERAL INFORMATION .....	1-1
Section I	Equipment Description and Data .....	1-1
CHAPTER 2	OPERATING INSTRUCTIONS.....	2-1
Section I	Description and Use of Operator's Controls and Indicators .....	2-1
Section II	Operation Under Usual Conditions.....	2-4
Section III	Operator's Preventive Maintenance Checks and Services .....	2-9
Section IV	Troubleshooting .....	2-13
CHAPTER 3	MAINTENANCE INSTRUCTIONS .....	3-1
Section I	Helmet Sizing and Fitting.....	3-1
Section II	Preventive Maintenance Checks and Services .....	3-3
Section III	Troubleshooting .....	3-5
Section IV	Cleaning .....	3-10
Section V	Aviation Unit Maintenance Procedures .....	3-11



**TABLE OF CONTENTS (Continued)**

		<u>Page</u>
APPENDIX A	REFERENCES .....	A-1
APPENDIX B	MAINTENANCE ALLOCATION CHART .....	B-1
APPENDIX C	REPAIR PARTS AND SPECIAL TOOLS LIST .....	C-1
APPENDIX D	EXPENDABLE SUPPLIES AND MATERIALS LIST .....	D-1

## CHAPTER 1

INTRODUCTION AND GENERAL INFORMATION

---

## Section I. EQUIPMENT DESCRIPTION AND DATA

**1-1. Equipment Characteristics, Capabilities, and Features.**

a. Purpose. This manual contains the instructions required by the Operator and Aviation Unit Maintenance personnel to use and maintain the SPH-4B Regular and Extra Large, Flyer's Protective Helmet. The SPH-4B (Figure 1 -1) provides flight personnel with head, ear, and eye protection and a means for radio communication.

b. Capabilities and Features.

- Lightweight design for demanding day and night missions.
- Impact-resistant helmet shell.
- Polystyrene energy-absorbing liner reduces impact forces.
- Inner thermoplastic liner provides a close fit and optimizes comfort.
- Adjustable retention assembly provides stability and optimizes fit in the chin and nape.
- Rotatable earcups reduce noise and flex to absorb lateral impact.
- Integrated communications system.
- Visor assembly provides retractable clear and neutral lenses and supports Aviator's Night Vision Imaging System (ANVIS) Night Vision Goggles (NVGs).

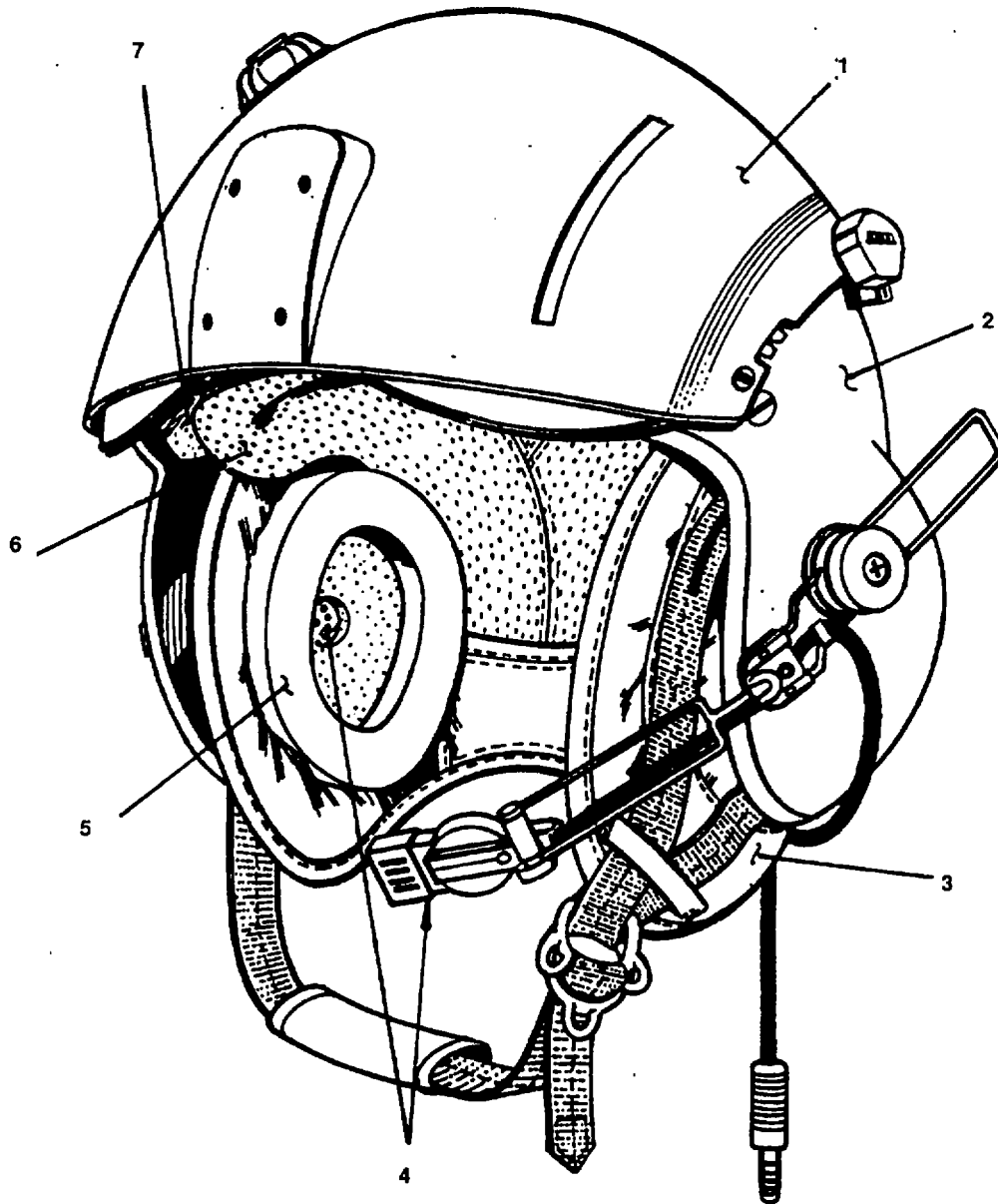

- 1. Dual visor assembly
- 2. Helmet shell
- 3. Retention assembly
- 4. Communications assembly
- 5. Earcup assembly
- 6. Thermoplastic liner (TPL)
- 7. Energy-absorbing liner

Figure 1-1. SPH-4B Helmet

## 1-2. Location and Description of Major Components.

a. **Helmet Shell (Figure 1-2).** Finished with rubber edge beading, the lightweight composite helmet shell (1) protects the head from impact. Chafing pads (2) prevent the earcups from chafing against the shell. Cross straps (3) regulate earcup tension, thereby controlling earseal compression for optimum fit and noise reduction.

b. **Liner System (Figure 1-2).** The SPH-4B liner system replaces the sling suspension systems of earlier SPH models. It consists of two liners: an energy-absorbing liner and a thermoplastic liner.

(1) **Energy Absorbing Liner.** The polystyrene energy-absorbing liner (5) absorbs and reduces impact forces. It is attached to the inside surface of the helmet shell with hook-and-pile fasteners.

(2) **Thermoplastic Liner.** The liner (4) is a lightweight comfort liner. It consists of layers of molded plastic attached to a removable, washable cloth cover. The sides of the cloth cover are made of pile fastener to attach the liner to hook-and-pile fastener on the inside surface of the energy-absorbing liner. The preformed liner fits most head shapes.

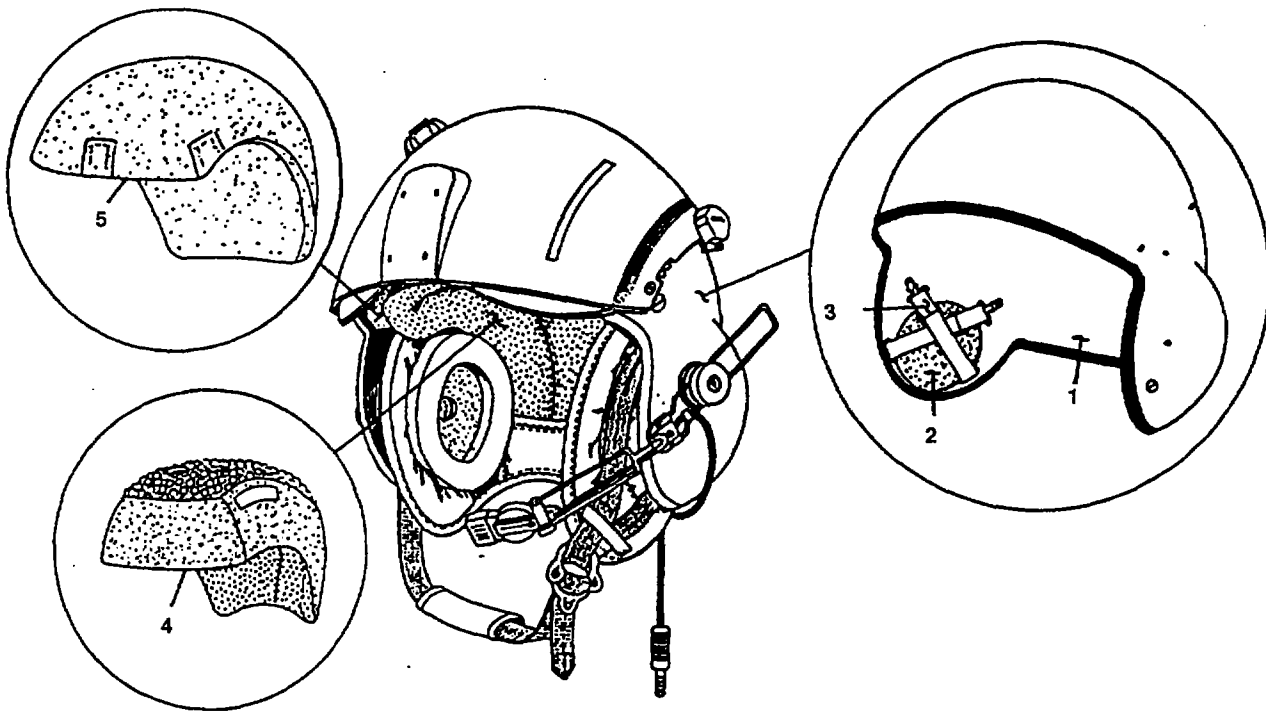

Figure 1-2. SPH-4B Helmet Shell and Liner System

c. Retention Assembly (Figure 1-3). The yoke-style retention assembly minimizes forward rotation of the helmet and reduces chinstrap stretch during use, thus providing a high level of protection. This assembly consists of V-shaped straps (1) for vertical earcup adjustment, a rear hanger tab (2) for vertical adjustment of the nape area, an adjustable chinstrap (3) with a double D-ring buckle, and adjustable rear nape strap (4) with a hook-and-pile closure for individual sizing.

d. Earcup (Figure 1-3). The earcups protect hearing by reducing noise; they also flex to absorb lateral impact. The earcups can be rotated within the retention assembly to optimize fit. Each earcup (6) features a cushioned earseal (9). An earphone holder (8) and a filler pad (7) house the earphone inside the earcup. If further fitting is needed, spacer pads (5) can be installed on the back of each earcup.

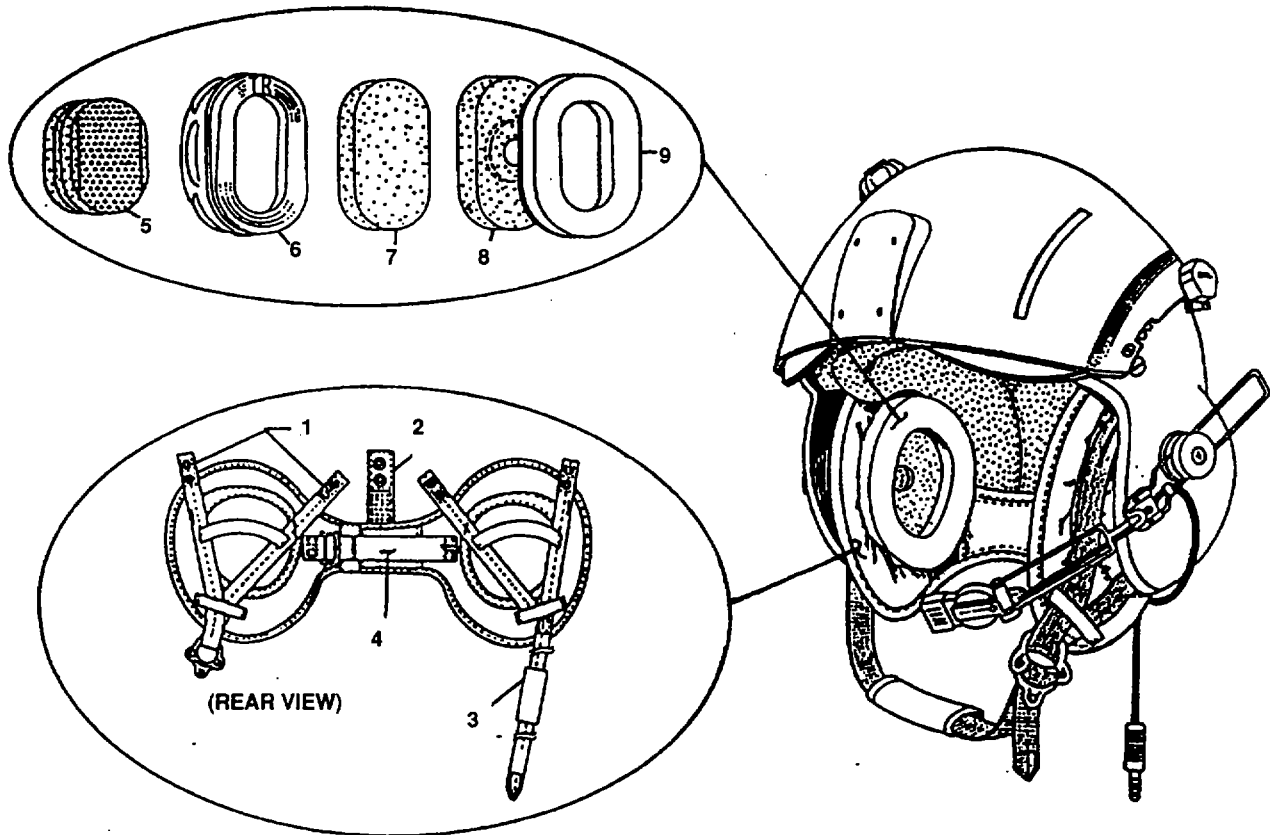

Figure 1-3. SPH-4B Retention and Earcup Assemblies

e. Communications System (Figure 1-4). The communications system consists of a boom-mounted adjustable microphone (5), a microphone cord (3), a communications cord (4) with a connector plug for radio communications, and a pair of earphones (6) housed inside the earcups. Refer to TM 11-5965-279-13&P, Operator, Aviation Intermediate Maintenance Manual, Including Repair Parts and Special Tools List for Headset-Microphone MK-896NA1 C Operating Instructions.

f. Lightweight Dual Visor Assembly (Figure 1-4). The ANVIS dual visor assembly protects the eyes from glare, dust, ballistic fragments, foreign particles, and flash fires. This assembly incorporates two polycarbonate visors: a clear outer visor (8) operated via an adjustable lock (1) and a neutral inner visor (7) operated via an attached actuating knob (2). The visor housing provides a mounting area (9) for a V-1 mount for ANVIS-6 night vision goggles.

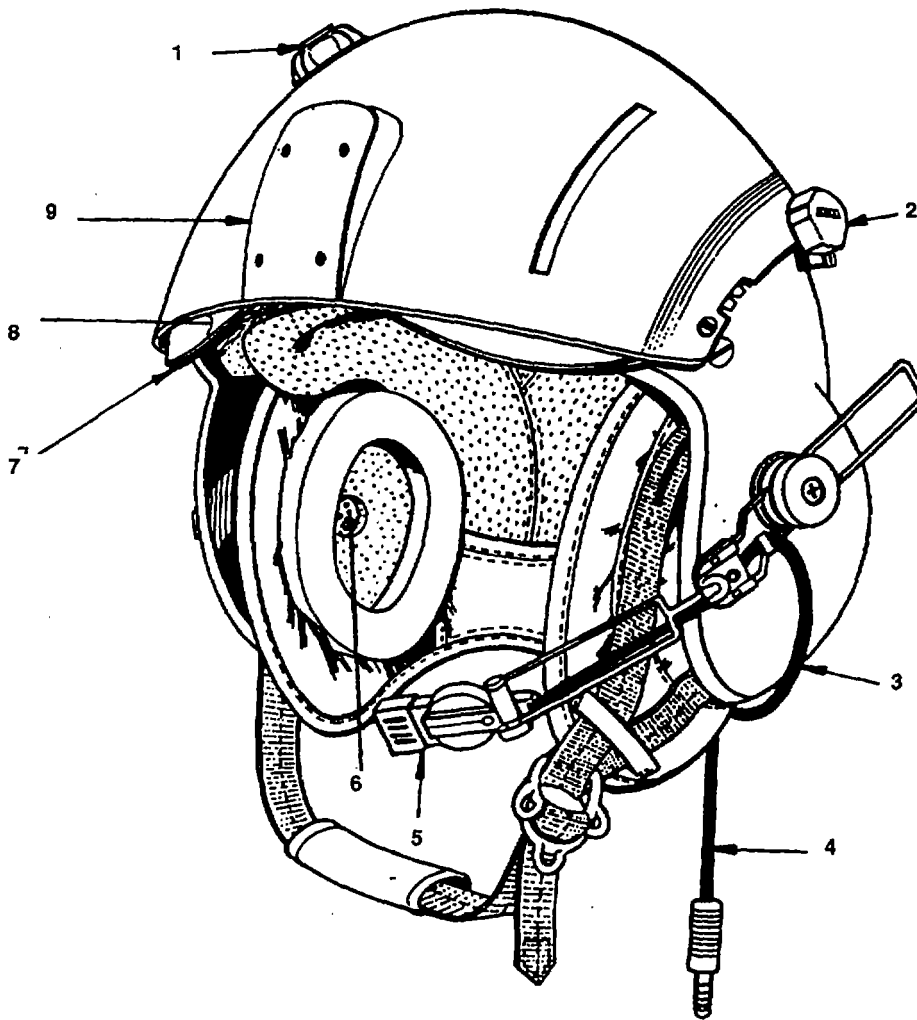

Figure 1-4. SPH-4B Communications System and Lightweight Dual Visor Assembly

**1-3. Differences Between Models.****NOTE**

The head measurements listed below are rule-of-thumb measurements.

- a. The helmet assembly accommodates three sizes of TPLs: small/regular, regular, and X-large (extra-large).
- b. The helmet shell and energy-absorbing liner are available in the regular and X-large sizes. The regular size fits head circumference from 21.5 inches to 22.4 inches; the X-large size fits head circumferences greater than 22.4 inches.
- c. Head circumferences of less than 21.5 inches require the smaller/regular size TPL, with a regular-size energy-absorbing liner installed in a regular-size helmet shell.
- d. Nutplates mounted on the inside of the shell, to prevent posts from spinning/turning, is optional. Ensure you know if your helmet is equipped with nutplates.

**1-4. Equipment Data.****Helmet Weight**

Regular - 50 ounces  
X-Large - 52 ounces

CHAPTER 2  
OPERATING INSTRUCTIONS

---

Section I. DESCRIPTION AND USE OF OPERATOR'S CONTROLS AND INDICATORS

**2-1. Controls, Description and Use.**

a. Chinstrap (Figure 2-1). The chinstrap (1) employs a double D-ring (5) for ease of tightening and loosening. A chinpad (2) allows added comfort. The length of the chinstrap allows for donning and doffing of the helmet without the need for repeated lacing through the D-rings.

b. Nape Strap (Figure 2-1). The nape strap features an adjustable hook-and-pile closure (3) for individual sizing and an adjustable buckle (4) to ensure a snug fit.

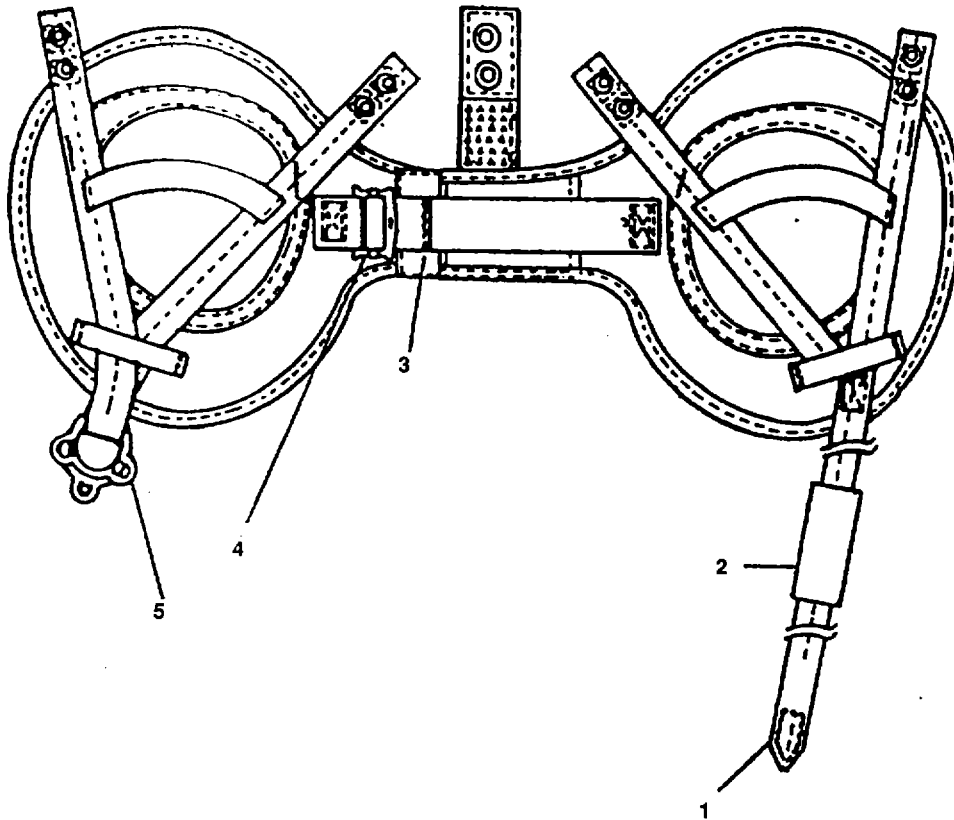

Figure 2-1. Chinstrap and Nape Strap



c. Earcups (Figure 2-2). If necessary, the earcups can be rotated within the retention assembly for optimum fit and noise reduction.

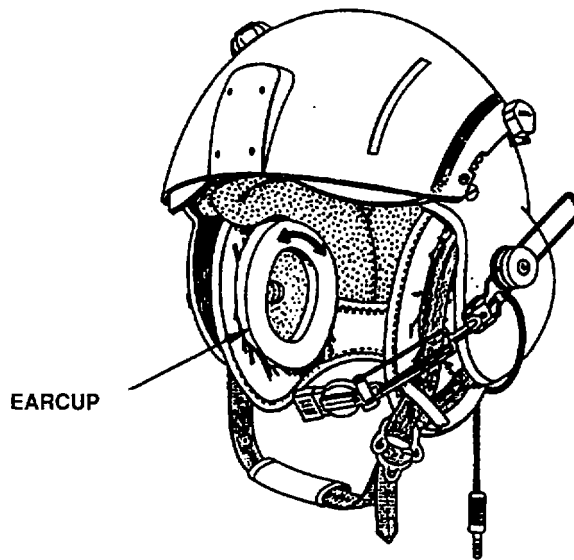

Figure 2-2. Earcup Within Retention Assembly

d. Cross Straps (Figure 2-3). The cross strap buckles can be adjusted for proper earcup tension by tightening and loosening as required (through trial and error).

e. Earcup Spacer Pads (Figure 2-4). If further earcup fitting is required after the cross straps have been adjusted, earcup spacer pads can be affixed to the earcups. Each earcup spacer pad set contains two thick pads and two thin pads; any number of pads can be used to suit individual needs. The pads can be cut to any size or shape needed (through trial and error) for the best earseal compression.

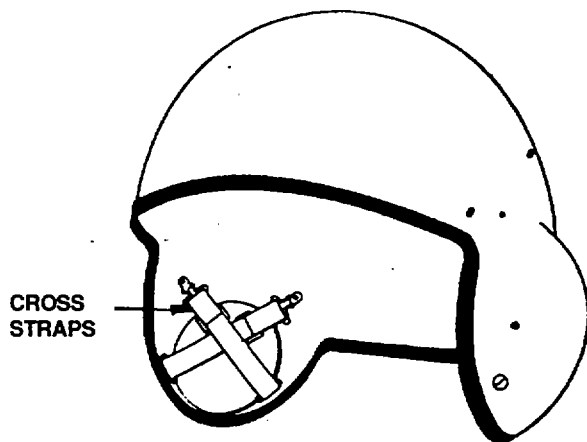

Figure 2-3. Cross Straps

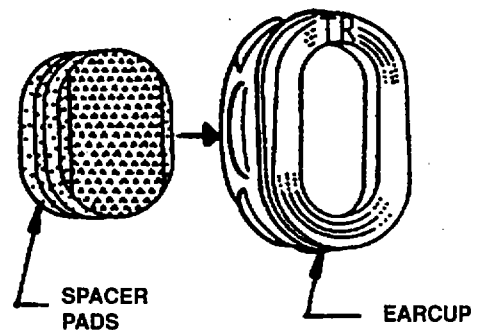

Figure 2-4. Earcup Spacer Pads

f. Boom and Headset-Microphone (Figure 2-5). The boom swivel assembly (1) allows for easy adjustment and location of the boom (2) and microphone (3).

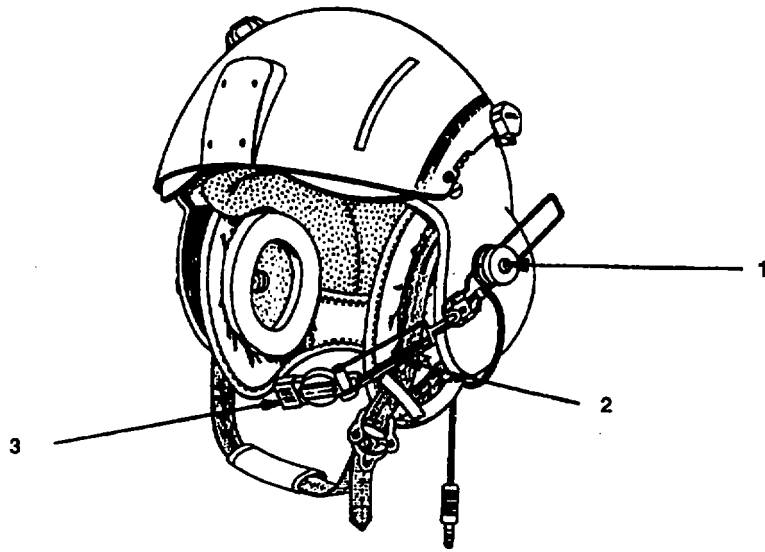

Figure 2-5. Boom and Headset-Microphone

g. Visor Mechanisms (Figure 2-6). The outer visor lock (1) raises and lowers the outer lens (3). The actuating knob (2) raises and lowers the inner lens (4). Both the outer visor lock and the actuating knob can be moved to the other side of the housing for right- or left-hand operation.

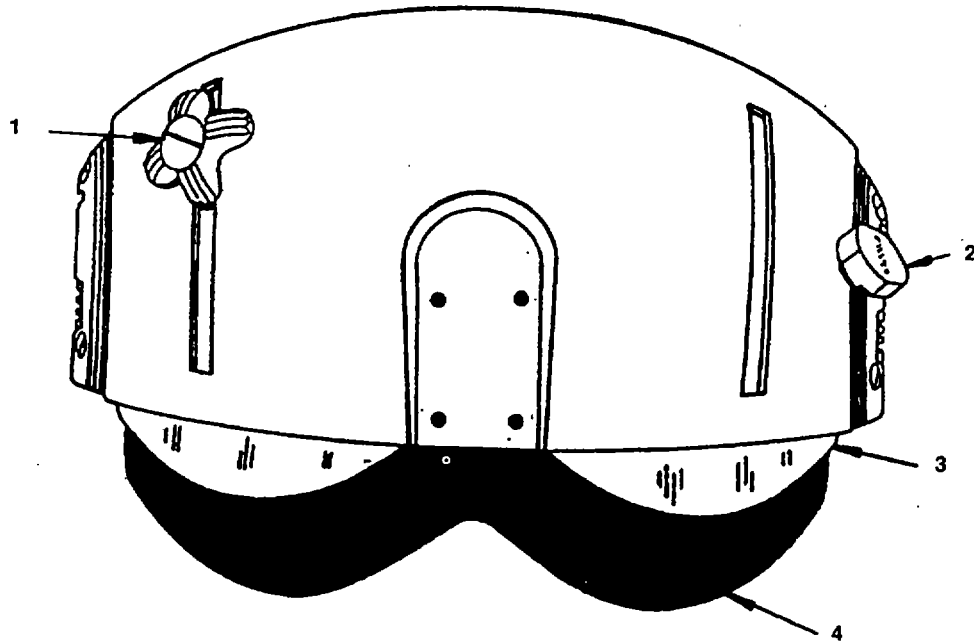

Figure 2-6. Visor Mechanisms

## Section II. OPERATION UNDER USUAL CONDITIONS

**2-2. General.** Operation of the SPH-4B consists of donning/doffing the helmet and operating the components.

### 2-3. Donning/Doffing Helmet.

#### CAUTION

Spread helmet only enough to allow ease of donning and doffing. Excessive spreading may damage helmet. Do not flex the helmet repeatedly.

#### a. Donning Helmet.

(1) Hook thumbs over earcups as shown in Figure 2-7, view A and spread helmet slightly.

(2) Position front edge of helmet firmly against forehead as shown in Figure 2-7, view B; rotate helmet rearward and down onto head.

(3) Press helmet down firmly with both hands to ensure that helmet is properly positioned onto head.

#### b. Doffing Helmet.

(1) Hook thumbs in earcups and spread helmet slightly.

(2) Rotate helmet toward rear and off head as shown in Figure 2-7, view C. If you prefer, you may rotate helmet forward and off head.

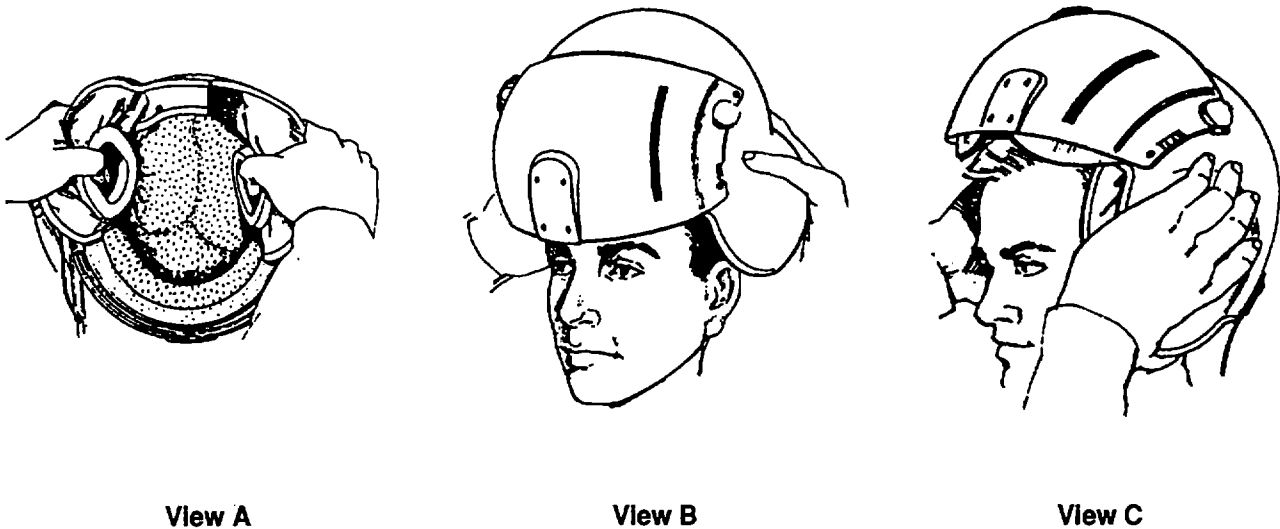

Figure 2-7. Donning/Doffing Helmet

## 2-4. Operation of Standard Components.

### a. Fastening/Adjusting Chinstrap.

(1) Fasten the chinstrap by inserting the strap through the D-rings, splitting the rings, and inserting the strap back through the inner D-ring.

(2) To tighten the chinstrap, pull it through the inner D-ring to attain the desired fit (Figure 2-8).

(3) To loosen the chinstrap, rotate the outer D-ring up and to the left by pulling on the two tabs of the outer D-ring. Pull the strap through the inner D-ring toward the left as needed to loosen or disengage the strap. If loosening, take up slack through D-rings by pulling the section of the strap under the chin to the right.

### NOTE

For most people, the chinstrap is long enough to allow for donning and doffing without repeated lacing through D-rings.

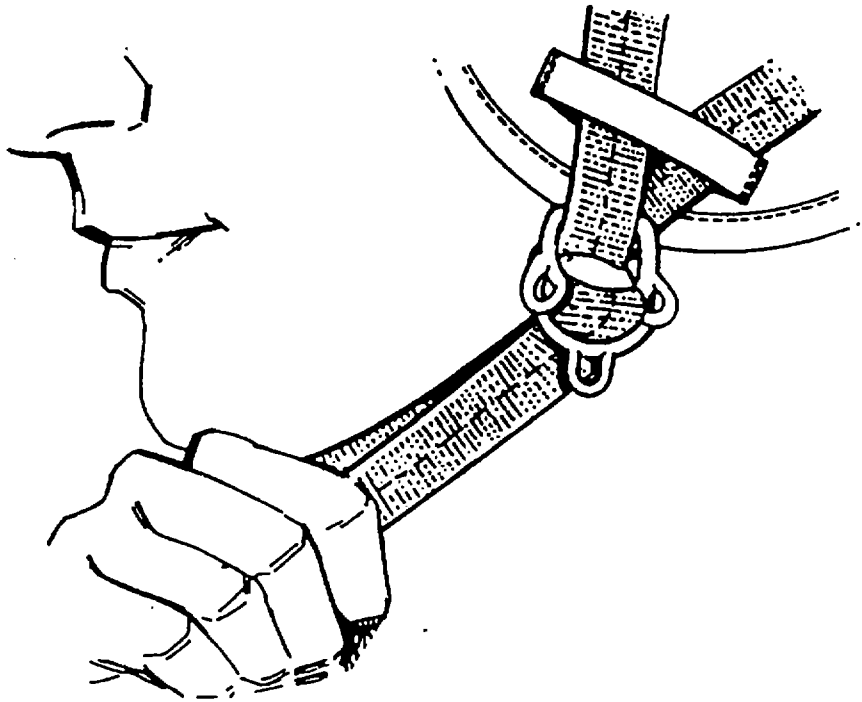

Figure 2-8. Fastening Chinstrap

b. Adjusting Nape Straps. Adjust nape straps as follows:

- (1) With helmet properly oriented on head, fasten hook-and-pile closure to fit nape area as closely as possible.
- (2) Pull strap through adjustment buckle and tighten to desired tension.
- (3) To loosen nape strap, pull strap back through adjustment buckle.

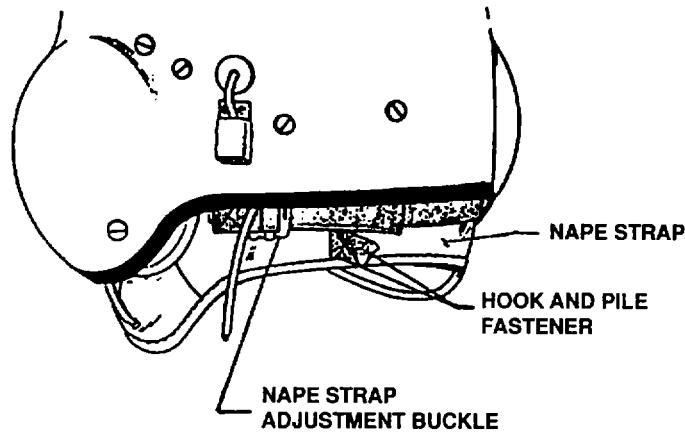

Figure 2-9. Nape Strap Adjustment

c. Adjusting Cross Strap. Move adjustment buckles upward or downward to tighten or loosen as required.

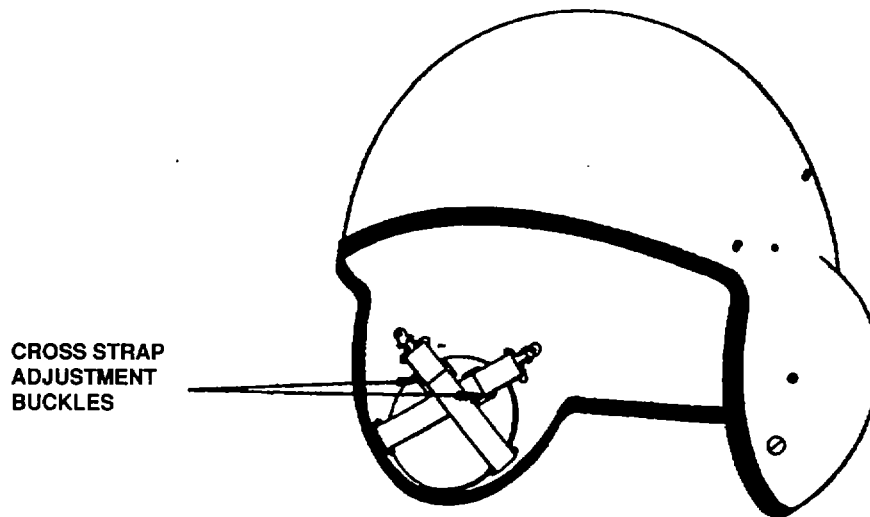

Figure 2-10. Cross Straps

d. Raising/Lowering Outer Visor. To raise or lower the outer visor, use the visor lock as follows:

- (1) Rotate the outer lock counterclockwise as shown in Figure 2-11 until the visor can be moved.
- (2) Raise or lower the outer visor by sliding the lock up or down along the track.
- (3) Lock the visor in the desired position by rotating outer lock clockwise (as worn) until it can no longer be rotated.

e. Raising/Lowering Inner Visor. To raise or lower inner visor, use the actuating knob as follows:

- (1) Squeeze the actuator knob as shown in Figure 2-11.
- (2) While squeezing the knob, raise or lower the inner visor by sliding the knob along the track.
- (3) Lock the visor in the desired position by releasing the knob into the desired detent slot.

f. Operating ANVIS Goggles. Refer to TM 11-5855-263-10, Operators Manual Aviators' Night Vision Imaging System, AN/AVS-6(V)1 and AN/AVS-6(V)2.

g. Operating Communications System. Refer to TM 11-5965-279-13&P, Operator, Aviation Intermediate Maintenance Manual, Including Repair Parts and Special Tools List for Headset-Microphone MK-896A/AIC Operating Instructions.

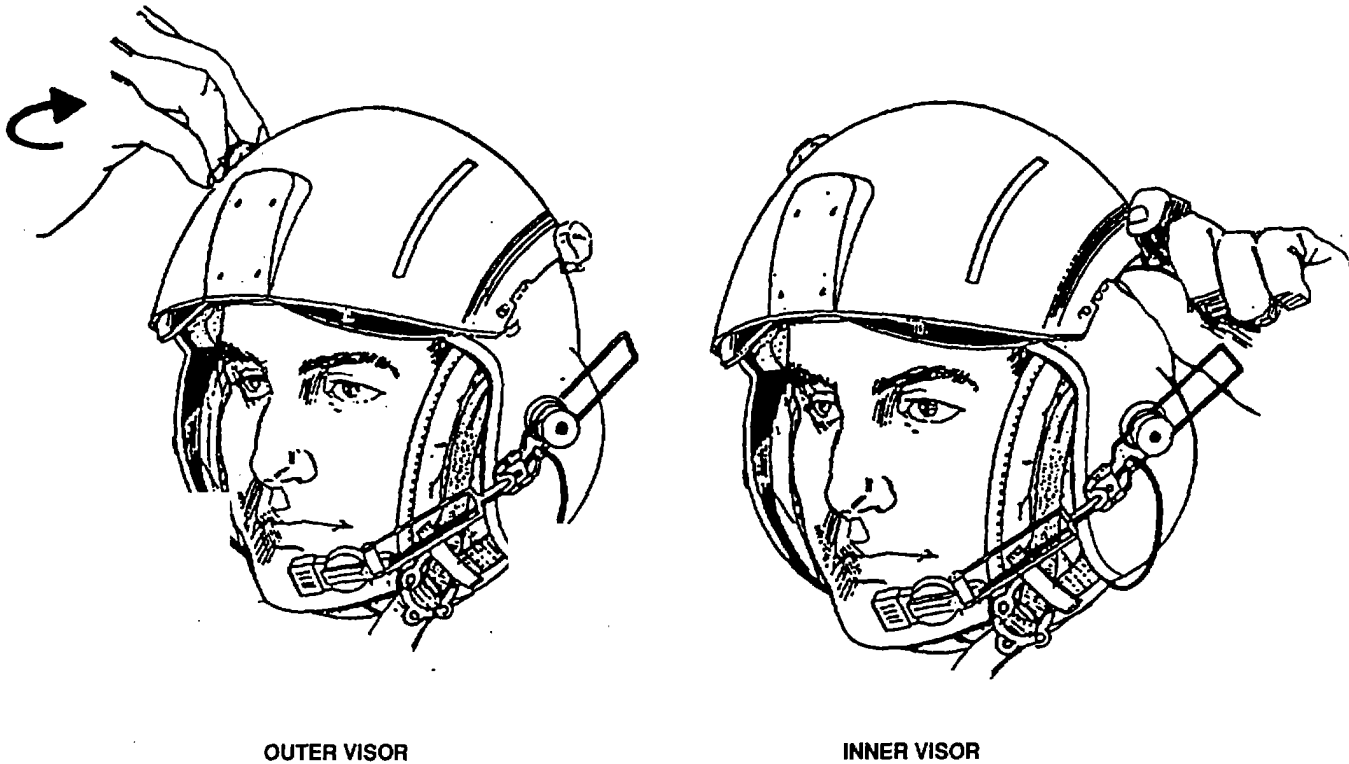

Figure 2-11. Raising/Lowering Visors

h. Applying earcup spacer pads. Use earcup spacer pads only if further fitting is required after cross straps have been adjusted. Apply the pads as follows:

**NOTE**

Steps 1 and 2 are not required if pressure-sensitive pile exists on back of earcups.

1. Peel backing from adhesive side of pad.
2. Press adhesive side of pad against back of earcup.

**NOTES**

- Spacer pads can be cut to any shape shown in figure 2-12 to balance earcup compression as needed.
- Use trial-and-error method when adding or trimming earcup spacer pads. Goal is to achieve optimum noise reduction and most comfortable fit.

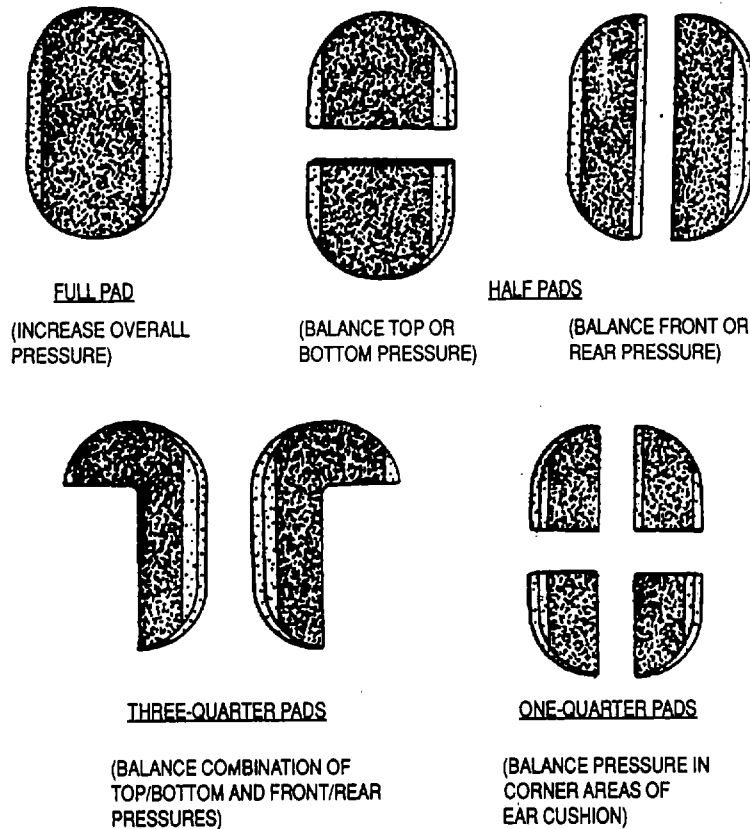

Figure 2-12. Spacer Pad Applications

## 2-5. Operation of Auxiliary Equipment.

- a. Operation of Headset-Microphone. Refer to TM 11 -5965-279-13&P, Operator, Aviation Intermediate Maintenance Manual, Including Repair Parts and Special Tools List for Headset-Microphone MK-896A/AIC operating instructions.
- b. Operation of Night Vision Goggles. Refer to TM 11-5855-238-10, Operator's Manual for Night Vision Goggles, AN/PVS-5 and AN/PVS-5A Operating Instructions and TM 11-5855-263-10, Operator's Manual Aviator's Night Vision Imaging System, AN/AVS-6(V) 1 and AN/AVS-6(V) 2.
- c. Operation of Helmet-Directed Fire Control Sub/System. Refer to TM 9-1270-212-14&P, Operator, Organizational, Direct Support and General Support Maintenance Manual (Including Repair Parts and Special Tools List and Depot Maintenance Repair Parts and Special Tools) for Fire Control Sub/System, XM-128 and XM-136 operating instructions.
- d. Operation of MBU 12/P Oxygen Mask. Refer to TM 55-1660-247-12/T.O. 15X5-3-6-1.
- e. Operation of Thermo Plastic Liner (TPL) Suspension Assembly.

The TPL suspension assembly replaces the current energy absorbing liner and the strap type suspension assembly and headbands.

The TPL assembly consists of an energy absorbing Liner, TPL layer assembly and a cloth TPL cover. When soiled the TPL cover can be removed and washed in warm soapy water and rinsed with clear warm water and air dried.



**Section III. OPERATOR'S PREVENTIVE MAINTENANCE CHECKS AND SERVICES (PMCS)**

- a. To insure that the helmet is ready for use at all times, deficiencies must be discovered and corrected before they result in serious damage or failure. All deficiencies and shortcomings will be recorded, together with corrective action taken, on DA Form 2404 (Equipment Inspection Maintenance Worksheet) at the earliest opportunity.
- b. Before you operate: Always keep in mind the CAUTIONS and WARNINGS. This is for your protection. Perform BEFORE (B) PMCS.
- c. While you operate: Always keep in mind the CAUTIONS and WARNINGS. Perform DURING (D) PMCS.
- d. After you operate: Be sure to perform AFTER (A) PMCS.
- e. If your equipment fails to operate, troubleshoot with proper equipment. Report any deficiencies using the proper forms. See DA PAM 738-751.
- f. Perform operators' preventive maintenance checks and services in accordance with table 2-1.
- g. Perform operators' PMCS on headset-microphone in accordance with TM 11-5965-279-13&P.
- h. Perform operators' PMCS on night vision goggles in accordance with TM 11-5855-263-10.
- i. Perform operators' PMCS on helmet directed fire control sub/system in accordance with TM 9-1270-212-14&P.
- j. Perform operators' PMCS on MBU-12/P oxygen mask in accordance with TM 55-1660-247-12/TO 15X5-3-6-1.
- k. After use and prior to stowing the helmet in the helmet bag: Wipe the ear cup cushion pads.

**Table 2-1. Operator's Preventive Maintenance Checks and Services**

**NOTE**

Within designated intervals, these checks are to be performed in the order listed.

The item number column shall be used as a source of item numbers for the "TM Number" column on DA Form 2404, in recording results of PMCS.

**LEGEND**

**B - Before**  
**D - During**

**A - After**  
**W - Weekly**

ITEM NO.	INTERVAL				Item To Be Inspected	PROCEDURES  Check for and have repaired or adjusted as necessary:	Equipment will be reported not ready/ Available if:
	B	D	A	W			
1.	●		●		<p><u>Upper Front</u></p> <p>Visor Locks</p>	<p>Inspect visor locks to make sure they lock in the retracted position. If defective visors lock refer to Chapter 3, Maintenance.</p>	<p>Visor locks fail to lock visors in retracted position.</p>
2.	●		●		<p>Visors and housing</p>	<p>Lower and raise visors to make sure they move freely in their tracks. If defective visors or visor tracks, refer to Chapter 3, Maintenance. Inspect visors for dust, grease, and other defects. using a clean, damp cloth, to remove dust and dirt.</p> <p><b>NOTE</b></p> <p>Use a mild soap solution to remove grease, oil and perspiration from visors.</p>	<p>Visors sticks or fail to move freely in tracks.</p> <p>Clean visors,</p>

Table 2-1. Operator's Preventive Maintenance Checks and Services (Continued)

ITEM NO.	INTERVAL				Item To Be Inspected	PROCEDURES Check for and have repaired or adjusted as necessary:	Equipment will be reported not ready/ Available if:
	B	D	A	W			
3.	●		●		<p><u>Lower Front</u></p> <p>Chin Strap</p>	<p>Inspect chin strap for frayed stitching, defective D-rings, buckle. If defective chin tab, refer to Chapter 3, Maintenance.</p>	<p>Stitching frayed, D-ring or buckle defective.</p>
4.	●		●		<p><u>Internal</u></p> <p>Retention Assembly</p>	<p>Inspect for tom fabric, damaged fasteners or defective buckle. If defective retention assembly, refer to Chapter 3, Maintenance.</p>	<p>Fabric is torn, buckle will not hold or fasteners are defective.</p>
5.	●		●		<p>Ear Cup tension, Cross Straps and Spacer Pads</p>	<p>Inspect cross straps for fraying, loss of elasticity, defective buckle or other obvious damage. spacer pads for looseness, deterioration or other damage. ive cross straps or spacer pads, refer to Chapter 3, Maintenance.</p>	<p>Cross straps are frayed, defective Inspect buckle, loss of elasticity. If defect-Spacer pads are loose or deteriorated.</p>
6.	●		●		<p>Liner</p>	<p>Inspect for looseness, cracks, stains, dents and gouges. Inspect for loose or missing hook fasteners. If defective liner, refer to Chapter 3 Maintenance.</p>	<p>Cracked and/or compressed more than 2 cubic centimeters in any one location.</p>
7.	●		●		<p>Ear Pad</p>	<p>Inspect for looseness or-deterioration. If damaged or defective ear pad, refer to Chapter 3, Maintenance.</p>	<p>Deteriorated or loose.</p>

Table 2-1. Operator's Preventive Maintenance Checks and Services (Continued)

ITEM NO.	INTERVAL				Item To Be Inspected	PROCEDURES Check for and have repaired or adjusted as necessary:	Equipment will be reported not ready/ Available if:
	B	D	A	W			
8.	●		●		<u>Outer Edge</u> Beading	Inspect for cracks, looseness or other defects. If defective beading, refer to Chapter 3, Maintenance.	Cracked, deteriorated, loose or missing beading.
9.	●		●		Microphone and Headset	Inspect for loose connection screws on rear attachment point on helmet; loose microphone or boom. or rear retainer clip plate is missing.	Screws are missing, microphone will not stay in position
10.	●		●		Night Vision Goggle Attachment Device	Inspect for loose screws.	Screws are loose.
11.	●		●		Hook & Pile	Inspect hook & pile to make sure it is not coming loose.	Hook & pile is coming loose.
12.	●		●		<u>Thermo Plastic Liner</u> TPL Cover	Inspect stitching to make sure they are not broken. Inspect for holes or worn spots. in cover.	Broken or missing stitching. Holes or worn spots
13.	●		●		Plastic Layer Assembly	Inspect for minimum of two layers. layers.	Less than two
14.	●				TPL Assembly	Insure proper fit of assembly on users head.	Proper fit cannot be made by minor adjustments.

**Section IV. TROUBLESHOOTING**

- a. Table 2-2 lists the common malfunctions which you may find during the operation or maintenance of the flyer's protective helmet or its components. You should perform the tests/inspections and corrective actions in the order listed.
- b. This manual cannot list all malfunctions that may occur, nor all tests and inspections and corrective actions. If a malfunction is not listed or is not corrected by listed corrective actions, refer to Chapter 3, Maintenance.
- c. Refer to TM 55-1660-247-12/TO 15 x 5-3-6-1 for troubleshooting procedures applicable to your Pressure-Demand Oxygen Mask, Type MBU-12/P.
- d. Refer to TM 11-5965-279-13&P for troubleshooting procedures applicable to your Headset-Microphone MK-896A/AIC.
- e. Refer to TM 9-1270-212-14&P for troubleshooting procedures applicable to your Helmet Directed Fire Control Subsystem, XM-128 and XM-136.
- f. Refer to TM 11-5855-263-10 for troubleshooting procedures applicable to your Night Vision Imaging System, AN/AVS-6(V)1 and AN/AVS-6(V)2.
- g. Be sure that your Preventive Maintenance Checks and Services have been applied before troubleshooting your equipment.

Table 2-2. Operators' Troubleshooting

MALFUNCTION	TEST OR INSPECTION	CORRECTIVE ACTION
1. OUTER LENS CANNOT BE RAISED OR LOWERED.	Check to see if visor lockwasher is installed with center cavity down, facing visor housing.	If not, correct it. If still unable to raise or lower, refer to Chapter 3, Maintenance.
2. INNER LENS CANNOT BE RAISED OR LOWERED.	Check to see if attaching screws are properly attached.	If not, refer to Chapter 3, Maintenance.
3. UNABLE TO ADJUST EARCUP COMPRESSION.	Inspect for loose or tight tension cross straps.	If unable to adjust earcup compression, refer to Chapter 3, Maintenance.
4. UNABLE TO ADJUST CHIN STRAP.	Refer to Chapter 3, Maintenance.	
5. UNABLE TO ADJUST NAPE STRAP.	Refer to Chapter 3, Maintenance.	
6. UNABLE TO KEEP MICROPHONE IN POSITION WHERE PLACED.	Inspect boom assembly for loose screws at mid point and at microphone end of boom.	If unable to tighten, refer to Chapter 3, Maintenance.
7. UNABLE TO HEAR.	Insure cord is plugged into receptacle and ICS box is working. Check left rear side of helmet and insure helmet connector is secured.	If still unable to hear, refer to Chapter 3, Maintenance.

CHAPTER 3

MAINTENANCE INSTRUCTIONS

Section I. HELMET SIZING AND FITTING

**3-1. General.** This section contains instructions for helmet sizing and fitting and replacing components.

**3-2. Helmet Sizing.** Helmet sizing and TPL selection are based upon circumference as follows:

HELMET SIZE	TPL SIZE	MAXIMUM HEAD CIRCUMFERENCE (INCHES)*
Regular	Small/regular	less than 21.5
Regular	Regular	21.5 - 22.4
X-Large	X-Large	greater than 22.4

\*Rule-of-thumb measurements only. At times, the next larger or smaller size may be required to achieve a satisfactory fit.

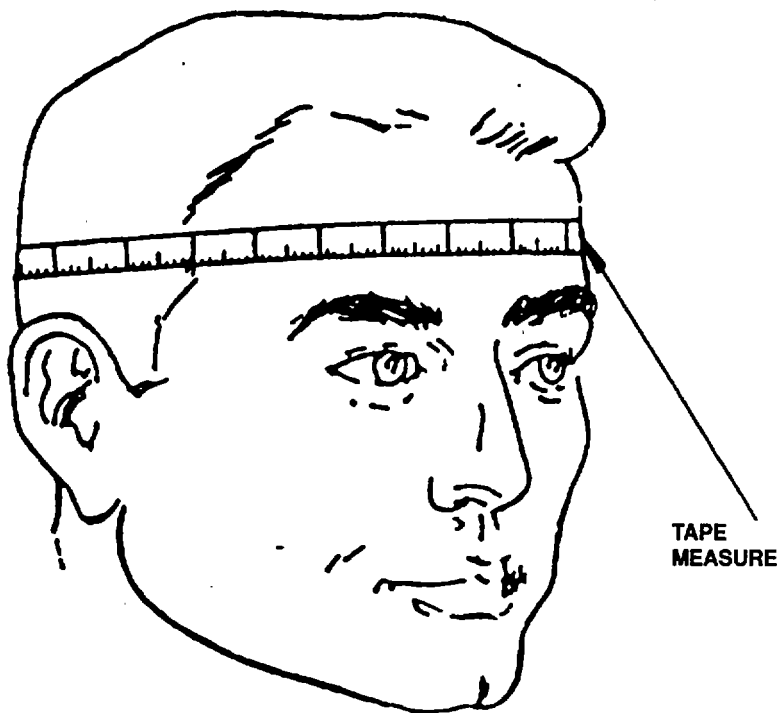

Figure 3-1. Head Circumference For Helmet Sizing

### 3-3. Basic Fitting Procedure.

#### NOTE

In preparation for fitting procedure, females with long hair should arrange their hair as they plan to wear it during flights.

Select proper helmet size and proceed as follows:

1. Don helmet, tighten nape strap, fasten chinstrap, and adjust earcups as required. Distance from eyebrow to shell should be approximately 3/4" when helmet is properly seated on head. If helmet fits but rear hanger tab of retention assembly is too long and chafes against neck, trim tab to proper length. Earcups can be rotated within retention assembly to improve fit to ear, if required. Ensure ears are centered in earcups.

2. Earseals should be compressed to the greatest degree possible without causing discomfort. For maximum earseal compression, helmet cross straps can be tightened. Two cross straps are located behind each earcup; each cross strap has a buckle. To tighten the cross strap, slide the buckle toward the bottom of the shell. Don helmet and check it.

3. If earseals are not sufficiently compressed when cross straps are tightened, earcup spacer pads may be added as required behind each earcup. Spacer pads may be cut to any size or shape necessary to achieve maximum compression.

4. Lower visors to check operation and nose clearance.

5. Check for hot spots or pressure points. If none are present, remove helmet, mark helmet with crewmember's identity, and store as required.

6. If helmet does not fit properly, i.e. it has hot spots or pressure points or fit is too tight or too loose, remove helmet. Repeat steps 1-6 using the next size larger or smaller helmet, as appropriate, if available. It may be necessary to remove one or more inner plastic layers from the TPL to achieve an optimum fit. Refer to TPL Removal/Installation, Paragraph 3-6. A minimum of two layers should be retained to meet performance requirements. If a proper fit can not be obtained, request authorization for custom fitting procedures from the Flight Surgeon.



3-3.1. Thermo Plastic Liner Custom Fitting Instructions.

**NOTE**

If the helmet does not fit properly, i.e. it has hot spots or pressure points or fit is too tight or too loose, remove helmet and custom-fit TPL following TPL custom fitting instructions.

- Tools and Equipment Required

1. Convection oven, capable of stabilized sustained temperature 200 degrees F  $\pm$  5 degrees F (93.3 degrees C  $\pm$  2.8 degrees C) with a thermometer and an internal volume of approximately 1.5 cubic feet or equivalent.

- 2. Timer or equivalent
- 3. Masking tape
- 4. Ruler

- Custom-Fitting Procedure

STEP	RESULTS/REMARKS
1. Set oven rack to lowest position; preheat oven to 200 degrees F $\pm$ 5 degrees F (93.3 degrees C $\pm$ 2.8 degrees F).	-Ensure oven stabilizes at approximately 200 degrees F.
2. Place TPL in preheated oven, fabric side on rack.	-Do not remove TPL cover; heat as a unit.
	-Place TPL in center of rack for even heating.
	-Caution applies only to non-convection ovens.
3. Allow oven to stabilize at temperature in step 1 before starting timed sequence.	-In helmet, cover hook fasteners (if installed) on rear of energy-absorbing liner with masking tape to ease TPL positioning when placing into helmet for custom fitting.

**CAUTION**

Ensure that upper burner elements do not activate during TPL heating process, or TPL plastic layers may melt.

4. Heat TPL for approximately 10 minutes.

- Set timer, stopwatch, or equivalent.

- Describe fitting procedure to crew-member.

- Check oven thermometer every three to five minutes during heating process and adjust oven controls if temperature falls outside the range specified in step 1.

5. Remove TPL from oven.

- Steps 5 through 10 should be completed in less than 30 seconds.

- Touch only fabric-covered portion of TPL.

- Gloves may be used for heat-sensitive hands.

**WARNING**

Do not touch hot plastic layers; burns may result.

6. Squeezing sides of TPL to clear earcups, place TPL in helmet.

- Place label and holes toward front of helmet.

7. Align TPL to protrude approximately 1/4" above front edge of styrofoam liner.

- Ensure that TPL is symmetrically located from side to side in helmet.

8. Position TPL crown into helmet.

- Do not press too hard in any one area; this may deform hot, soft TPL.

9. Have crewmember hook thumbs in earcups, spread helmet slightly, place front of helmet against brow, rotate helmet rearward, and don helmet.

- Technician should squeeze rear portion of TPL tightly against styrofoam liner during donning to ensure that TPL does not bunch up in rear.

- Helmet should now be in proper position.

10. Have crewmember pull helmet down until ears are centered in earcups.

- Hold for three to five minutes.

- Chin strap may be fastened to hold helmet in position.

11. Check eyebrow-to-shell offset.

- Shell should be approximately 3/4" above eyebrow for maximum field of view.

- Lower visors to check centering and nose clearance.

12. Release pressure on top of helmet at the end of three to five minutes.

-Raise visors.

-Adjust rear-closure hook-and-pile fasteners and hanger tab of retention assembly; adjust earcups; tighten nape strap and chin strap as required.

13. Check fit.

-Check for hot spots or pressure points.

-TPL can be reheated and fitting procedures repeated. Remove masking tape from rear hook fasteners before reheating.

-TPL layers can be laundered or dry cleaned. Replace two-sided tape after laundering.

-In some cases it will be necessary to remove one or more inner plastic layers from TPL to achieve an optimum fit. A minimum of two layers should be retained.

Change 2 3-2.3/(3-2.4 blank)

**Section II. PREVENTIVE MAINTENANCE CHECKS AND SERVICES (PMCS)**

- a. Preventive Maintenance Checks and Services (PMCS), Table 3-1, are to be done to be sure the helmet is ready for use at all times. These checks and services help you find and fix defects before the helmet is damaged or fails.
- b. Item numbers in the first column on Table 3-1 are the order in which things are to be done. Column two "Interval" lists when to do them.
- c. If minor defects are found when the helmet is in use, take notes on what they are. Fix them, or have them fixed after you have stopped using the helmet.
- d. Record all defects and steps taken to fix them on DA Form 2404 (Equipment Inspection and Maintenance Work Sheet) as soon as possible. Use of DA Form 2408-22 is also required.

**NOTE**

Always keep in mind the WARNINGS located on the inside front cover. Perform BEFORE (B) PMCS.

**Table 3-1. AVUM Preventive Maintenance Checks and Services**

**LEGEND**

**DA - Days      Q - Quarterly**

Item No.	Interval		Item to be Inspected	Procedures	Equipment will be reported not ready/ available if:
	DA	Q			
1.	120		Visor locks	Inspect visor locks to insure they locks visors in retracted position.	Lock fails to hold visors in retracted position.
2.	120		Visors	Inspect for cracks, blemishes or scratches.	Cracked, blemished or scratched.

Table 3-1. AVUM Preventive Maintenance Checks and Services (Continued)

## LEGEND

DA - Days      Q - Quarterly

Item No.	Interval		Item to be Inspected	Procedures	Equipment will be reported not ready/ available if:
	DA	Q			
3.	120		Visor tracks and spacers	Inspect for cracks, excessive wear (that would make them inoperative), breaks or missing mounting hardware.	Any mounting hardware is missing or defective, tracks are worn enough to make them inoperative.
4.	120		Visor housing	Inspect paint for blemishes or chips. Spot paint as required.	
5.	120		Chin strap	Inspect for tears, rips, frayed stitching or defective D-rings.	Chin strap is torn or stitching is badly frayed. D-rings are bent or broken.
6.	120		Retention assembly	Inspect for defective or missing mounting hardware, torn fabric, damaged fasteners, or defective adjustment buckle.	Adjustment buckle is defective, fasteners are defective or fabric is torn.
7.	120		Ear cup tension cross straps, and spacer pads	Inspect spacer pads for deterioration, cross straps for rips or tears.	Cross straps are torn or ripped, spacer pads (if used) are loose or deteriorated.
8.	120		Beading	Inspect for chips, looseness, dry rot or weather checking.	Missing or loose.

**Table 3-1. AVUM Preventive Maintenance Checks and Services (Continued)**

**LEGEND**

DA - Days      Q - Quarterly

Item No.	Interval		Item to be Inspected	Procedures	Equipment will be reported not ready/ available if:
	DA	Q			
9.	120		Liner	Inspect for cracks or looseness.	
10.	120		Shell	Inspect for cracks, dirt, damaged paint or marking.	Shell is cracked.
11.	120		Jack Plate	Inspect for loose screws and missing jack plate	If screws or jack plate are missing.
12.	120		Night Vision Goggles Mounting System	Inspect for loose screws and excessively loose hook and pile.	If screws or hook and pile are excessively loose.
13.	120		Thermo Plastic Liner assembly TPL	Inspect for excessively loose hook and pile.	If hook and pile are excessively loose.

**Section III. TROUBLESHOOTING**

Table 3-2 contains troubleshooting information useful to you in diagnosing and correcting malfunctions or unsatisfactory operation of the flyer's protective helmet.

- a. The troubleshooting table lists the common malfunctions and unsatisfactory conditions you are most likely to run into.
- b. You should first find the malfunction in the table which most closely describes the problem; then perform the tests, inspections and corrective actions in the order in which they are listed.
- c. This manual cannot list all possible symptoms which may occur. If a condition exists which cannot be resolved by you, notify your supervisor.
- d. For troubleshooting information applicable to the operation of the Headset-Microphone Model MK-896A/AIC, refer to TM 11 -5965-279-13&R

e. For troubleshooting information applicable to the operation of the Night Vision Goggles Model AN/AVS-6(V)1 and AN/AVS-6(V)2, refer to TM 11-5855-263-10.

f. For troubleshooting information applicable to the operation of the Helmet Directed Fire Control Subsystem Model XM-128 and XM-136, refer to TM 9-1270-212-14&P.

g. For troubleshooting information applicable to the operation of the Oxygen Mask, MBU-12/P, refer to TM 55-1660-247-12 or TO 15X5-3-6-1.

h. You should verify the fault before performing troubleshooting.

**Symptom Index**

	<b>Troubleshooting Procedure</b>
<b>VISOR</b>	
Cannot be lowered	1
Cannot be raised	1
<b>CHIN STRAP</b>	
Unable to adjust	3
Unable to attach	4
<b>NAPE STRAP</b>	
Unable to adjust	5
<b>EAR CUP COMPRESSION</b>	
Unable to adjust	2
<b>MICROPHONE</b>	
Unable to keep in position	6

Table 3-2. AVUM Maintenance Troubleshooting Chart

MALFUNCTION	TEST OR INSPECTION	CORRECTIVE ACTION
-------------	--------------------	-------------------

1. VISOR CANNOT BE RAISED OR LOWERED.

Step 1. Inspect for defective visor lock.

Replace visor lock per paragraph 3-12.

Step 2. Check for improperly installed visor lock.

Make certain lockstem on outer visor lock has been rotated 90°.

Step 3. Inspect for defective visor.

Replace visor per paragraph 3-12.

Step 4. Inspect for missing or defective spacer(s).

Replace spacer(s) per paragraph 3-12.

Step 5. Inspect for defective visor tracks.

Replace visor tracks per paragraph 3-12.

Step 6. Inspect for defective visor housing.

Replace visor housing per paragraph 3-12.

2. UNABLE TO ADJUST EAR CUP COMPRESSION.

Step 1. Inspect for worn or defective tension cross straps.

Replace per paragraph 3-17.

Step 2. Ear cup spacers are required or are defective.

Replace per paragraph 3-17.



Table 3-2. AVUM Maintenance Troubleshooting Chart (Continued)

MALFUNCTION	TEST OR INSPECTION	CORRECTIVE ACTION
-------------	--------------------	-------------------

## 3. UNABLE TO ADJUST CHIN STRAP

Inspect for defective chin strap.

Replace defective chin strap per paragraph 3-7.

## 4. UNABLE TO ATTACH CHIN STRAP

Inspect for defective D-Ring.

Replace chin strap retention assembly per paragraph 3-7.

## 5. UNABLE TO ADJUST NAPE STRAP.

Inspect for defective buckle and worn strap.

Replace retention assembly per paragraph 3-7.

## 6. UNABLE TO KEEP MICROPHONE IN POSITION.

Step 1. Inspect for loose connecting screw in center of boom.

Replace if unable to tighten.

Step 2. Inspect for loose connecting screws at end of mike boom.

Replace if unable to tighten.

Table 3-2. AVUM Maintenance Troubleshooting Chart (Continued)

MALFUNCTION	TEST OR INSPECTION	CORRECTIVE ACTION
7. UNABLE TO KEEP NIGHT VISION GOGGLES MOUNTED TO THE HELMET.		Refer to TM 11-5855-263-10.
8. THERMO PLASTIC LINER (TPL) ASSEMBLY.		<p data-bbox="188 543 672 575">Unable to keep TPL assembly in helmet.</p> <p data-bbox="188 604 1170 636">Check hook and pile fasteners for secure attachment to helmet, liner or TPL layers.</p> <p data-bbox="188 665 1240 697">Check hook and pile for dirt, lint or anything that will keep surfaces from mating properly.</p> <p data-bbox="188 726 711 758">Check alignment of hook and pile fasteners.</p> <p data-bbox="285 787 789 819">    Replace defective hook and pile fasteners.</p> <p data-bbox="285 848 737 879">    Clean lint or dirt out of hook fasteners.</p> <p data-bbox="285 909 764 940">    Properly realign hook and pile fasteners.</p>

## Section IV. CLEANING

**3-4. General.** The operator should clean the helmet as needed, following the cleaning methods listed in Table 3-3.

Table 3-3. Cleaning Methods

COMPONENT	CONDITION	CLEANING METHOD
Helmet shell	Dirt, grease, scuff marks	Mild soap solution and clean cloth.
Earcups	Dirt, perspiration	Wipe with damp cloth; to protect earphones, do not use excessive water.
Cord assembly connector	Dirt, grease	Wipe with damp cloth; dry thoroughly
Visor lenses	Dust, grease, perspiration	Soft cloth and mild soap solution; rinse with clean water.
Visor housing, tracks, knob	Sediment, dirt, buildup, grease	Clean cloth dampened with mild soap solution.
Retention assembly	Dirt, grease	Clean cloth dampened with mild soap solution. Allow to dry thoroughly.
Cloth cover, thermoplastic liner	Dirt, stains	Machine wash (gentle cycle) or hand wash with soap and warm water and allow to dry.
Plastic layers, thermoplastic liner	Dirt	Hand wash, soap and water only, air dry.

**Section V. AVIATION UNIT MAINTENANCE PROCEDURES****NOTE**

Most procedures in this section consists of removal and installation of components. The exceptions are as follows:

- Edge beading and chafing pads. Edge beading and chafing pads are already installed on the helmet shell. The sole purpose of these procedures is to replace worn edge beading or chafing pads.
- Painting. This procedure details the painting of the helmet shell and/or the visor housing to cover chipped paint.
- ANVIS mount and goggles. These procedures simply cover attachment of these components.

---

**3-5. Energy-Absorbing Liner and Thermoplastic Liner.**

---

**INITIAL SETUP TABLE**

<b>TOOLS</b>	<b>MATERIALS/PARTS</b>	<b>PERSONNEL REQUIRED</b>
<ul style="list-style-type: none"> <li>• General Aircraft Mechanics Tool Kit</li> </ul>	NONE	A.L.S.E. Specialist/Technician or Personnel with ASI of H2/02 (ALSE Qualified)
<ul style="list-style-type: none"> <li>• Spatula/Tongue depressor</li> </ul>		

**NOTE**

In many cases, it is possible to remove the energy-absorbing liner without removing the earcups. You may wish to bypass Removal step 2 and Installation step 3.

**Removal**

1. Squeezing sides of thermoplastic liner, remove it from helmet (Figure 3-2).
2. Remove earcups from retention assembly per paragraph 3-8, removal steps 1 thru 5. Allow earcups to hang by communications cord.
3. Using any type of flat tool (flat-tip screwdriver, spatula, tongue depressor, etc.) separate hook-and-pile fastener attaching energy-absorbing liner to helmet shell; slide liner out through back of helmet.

**Installation****NOTE**

Install nut plate (if available) or glue all four visor posts.

1. Slide replacement energy-absorbing liner into helmet (use spatula). Apply slight pressure to engage hook-and-pile fasteners.

**NOTE**

Holes in plastic layers and label on cloth cover should be positioned toward the front of the helmet (Figure 3-3).

2. Squeezing sides of thermoplastic liner, reinstall it in helmet (see Figure 3-2). Ensure hook-and-pile fasteners are engaged.
3. Reinstall earcups per paragraph 3-8, Installation steps 2 and 3.

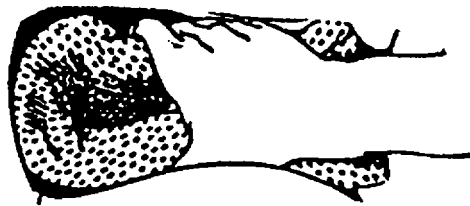

**Figure 3-2. Liner Removal/Installation**

**3-6. Thermoplastic Liner.**

**INITIAL SETUP TABLE**

TOOLS	MATERIALS/PARTS	PERSONNEL REQUIRED
<ul style="list-style-type: none"> <li>General Aircraft Mechanics Tool Kit</li> </ul>	Tape, double-sided	A.L.S.E. Specialist/Technician or Personnel with ASI of H2/Q2 (ALSE Qualified)

**Removal**

1. Remove liner per paragraph 3-5, Removal step 1.
2. Remove liner cloth cover as follows:
  - (a) Fold sides of cover down to expose double-sided tape.
  - (b) Remove cover from layer assembly.
  - (c) Remove double-sided tape from layer assembly.

**Installation**

1. Install liner cloth cover as follows:
  - (a) Cut two 2-1/2-inch pieces of double-sided tape.
  - (b) Attach a piece of tape to each side of layer assembly (where old tape was removed).

**NOTE**

Holes in plastic layers and label on cloth cover should be positioned toward the front of the helmet. (See Figure 3-3.)

(c) Fold sides of replacement cloth cover back; place layer assembly against cloth cover; fold sides of cloth cover over layer assembly.

(d) Reinstall liner per paragraph 3-5, Replacement step 2.

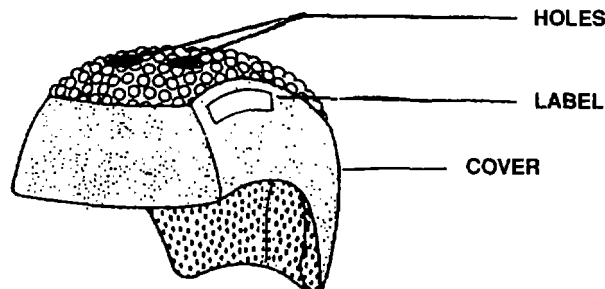

**Figure 3-3. Liner Assembly**

**3-7. Retention Assembly.**

**INITIAL SETUP TABLE**

TOOLS	MATERIALS/PARTS	PERSONNEL REQUIRED
<ul style="list-style-type: none"> <li>General Aircraft Mechanics Tool Kit</li> </ul>		A.L.S.E. Specialist/Technician or Personnel with ASI of H2/Q2 (ALSE Qualified)
<ul style="list-style-type: none"> <li>Scissors</li> </ul>		

**Removal**

1. Remove earcups from retention assembly in helmet per paragraph 3-8.
2. Remove thermoplastic liner and energy-absorbing liner from helmet per paragraph 3-5.
3. Remove screws, washers, and posts securing retention assembly and rear cross straps to helmet.

**Installation**

**NOTES**

- The yoke-style retention assembly contains two holes (eyelets) in each strap. The recommended installation procedure is to use the lower strap holes in the size regular helmet and the upper strap holes in the size x-large helmet. However, if the helmet does not fit properly with the retention installed in this manner, the settings may be changed as required.
- The front retention straps on each side raise and lower the earcups.
- The rear retention straps control the forward and aft earcup positioning.
- The rear hanger tab adjusts the nape pad. This tab may be trimmed to prevent chafing on the neck.



1. Attach retention assembly to helmet (see Figure 3-4) using screws, washers, and posts supplied. For the front retention strap/cross strap attachment (one place each side), secure using a 1/4" screw, a washer, and a 3/16" post (Figure 3-4, View A). For rear cross strap attachment (one place each side), secure using a 3/16" screw, a washer, and a 1/16" post (Figure 3-4, View B). For rear retention strap installation (one place, rear of helmet), secure using a 1/4" screw, a washer, and a 1/8" post (Figure 3-4, View C).

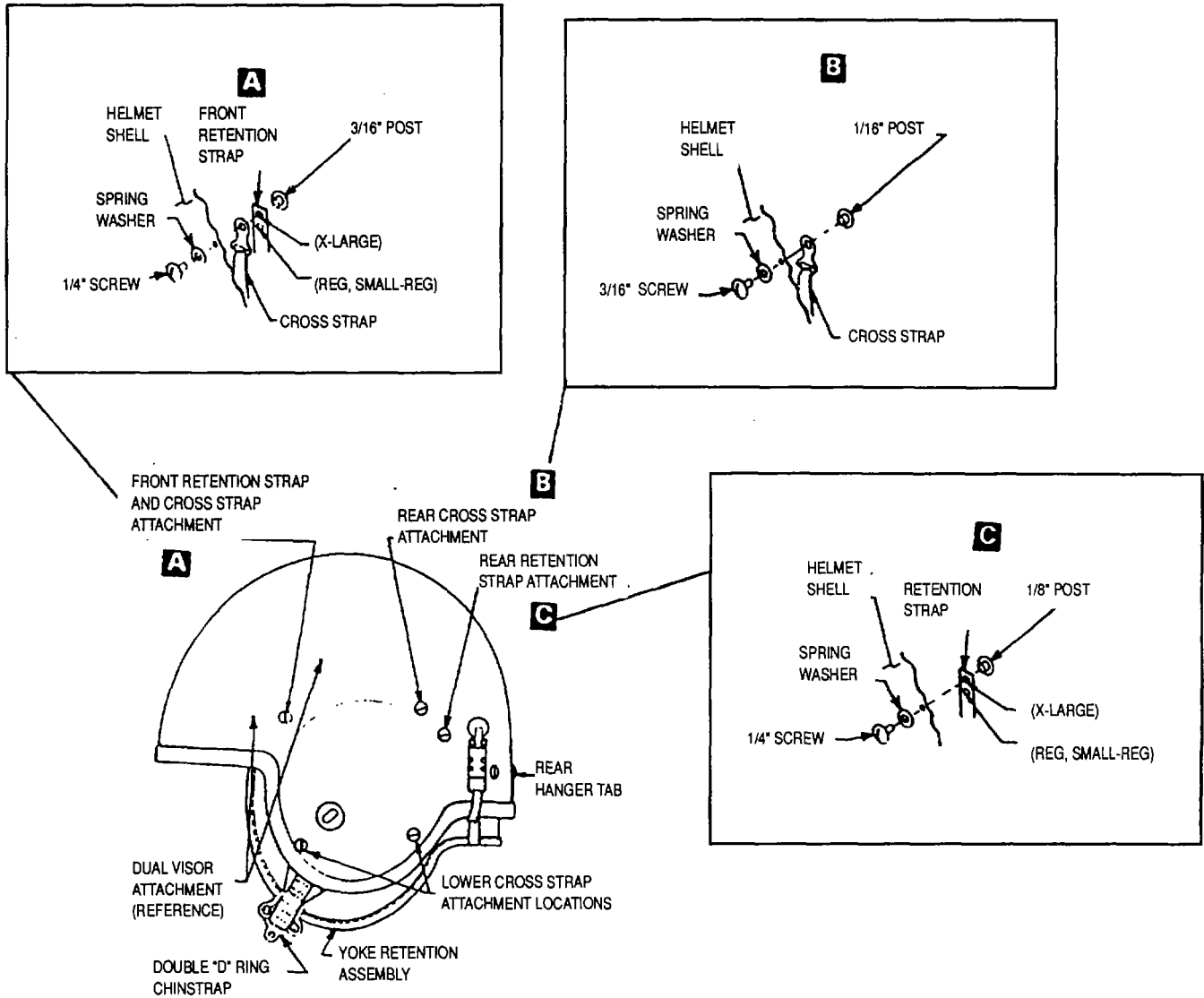

Figure 3-4. Retention Assembly Attachment Points

2. Install energy-absorbing liner and thermoplastic liner, paragraph 3-5, steps 1-3.
3. Install earcups in retention per paragraph 3-8.
4. Don helmet.
5. Adjust earcups to a comfortable fit.
6. At nape area, adjust hook-and-pile closure to a snug fit. Tighten adjustment buckle strap as required. Adjust rear hanger tab and trim if required. Figure 3-5 shows how the hanger tab is trimmed.
7. Adjust chinstrap as required.
8. Remove helmet and store as required.

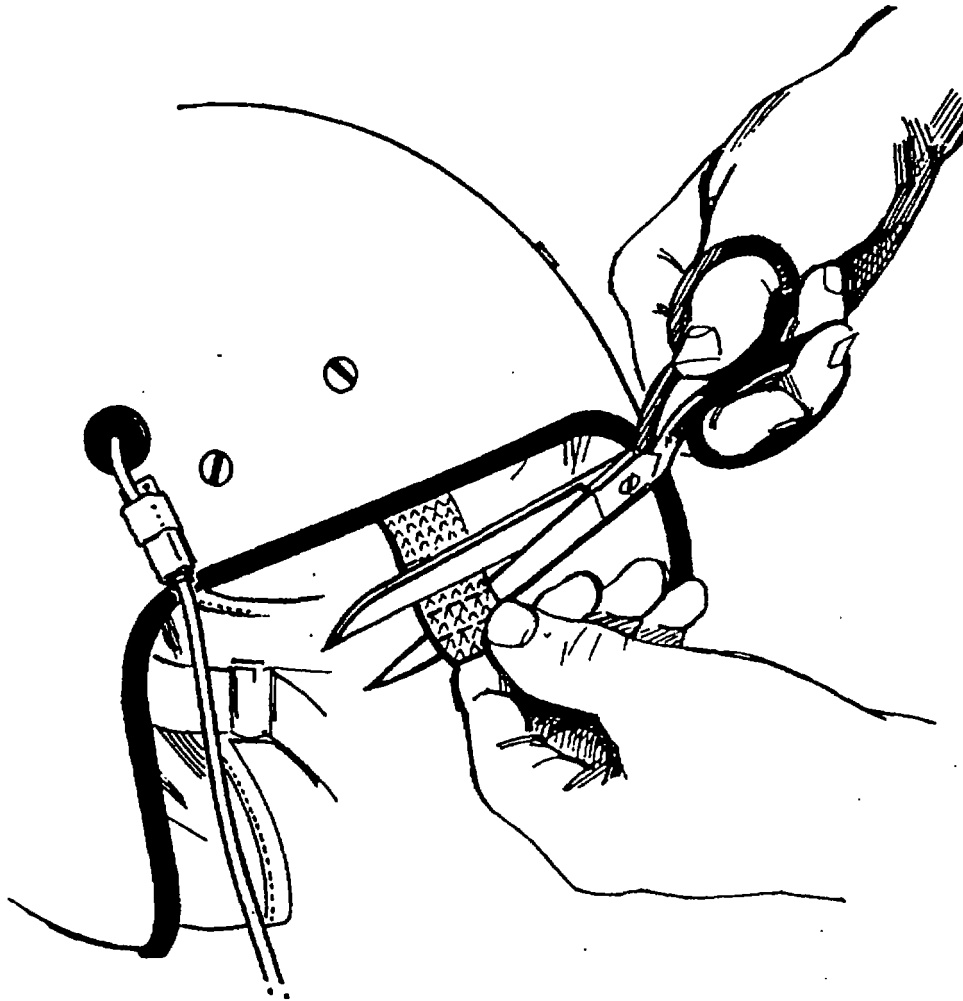

Figure 3-5. Trimming Hanger Tab

**3-8. Earcups and Earphones.**

**INITIAL SETUP TABLE**

TOOLS	MATERIALS/PARTS	PERSONNEL REQUIRED
<ul style="list-style-type: none"> <li>General Aircraft Mechanics Tool Kit</li> </ul>		A.L.S.E. Specialist/Technician or Personnel with ASI of H2/Q2 (ALSE Qualified)

**Removal**

1. Carefully remove cushion insert earphone and earphone from earcup; do not pull the wires out of the terminals.

**NOTE**

Some earphone leads are secured with internal wrenching set screws requiring an hex key for removal. Others are secured with common slotted screws.

2. Remove cord leads from earphone using a small flat-tip screwdriver or hex key as required.
3. Remove rubber grommet and communications cord from earcup.

**NOTE**

You are now ready to remove earcup. To make this task easier, it is recommended that you begin by rotating earcup a quarter turn counterclockwise.

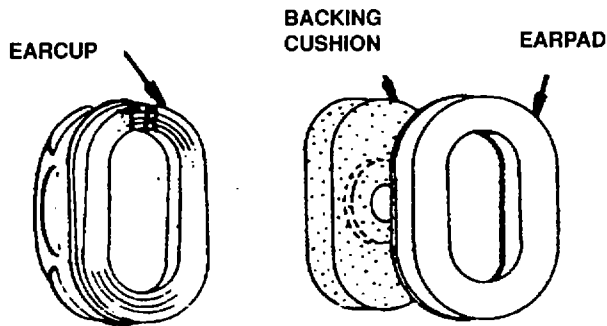

**Figure 3-6. SPH-4B Earcup Assembly**

**CAUTION**

- When removing earcup from retention, be careful not to tear retention with screwdriver or awl.
- Do not bend earcup tabs, or they will break.

4. Insert small flat-tip screwdriver or awl between earcup and retention assembly (see Figure 3-7) to create a small opening. Working around edge of earcup, carefully use screwdriver or awl to lift retention assembly away from earcup tabs. Remove earcup from retention assembly.

5. Repeat procedure for other earcup.

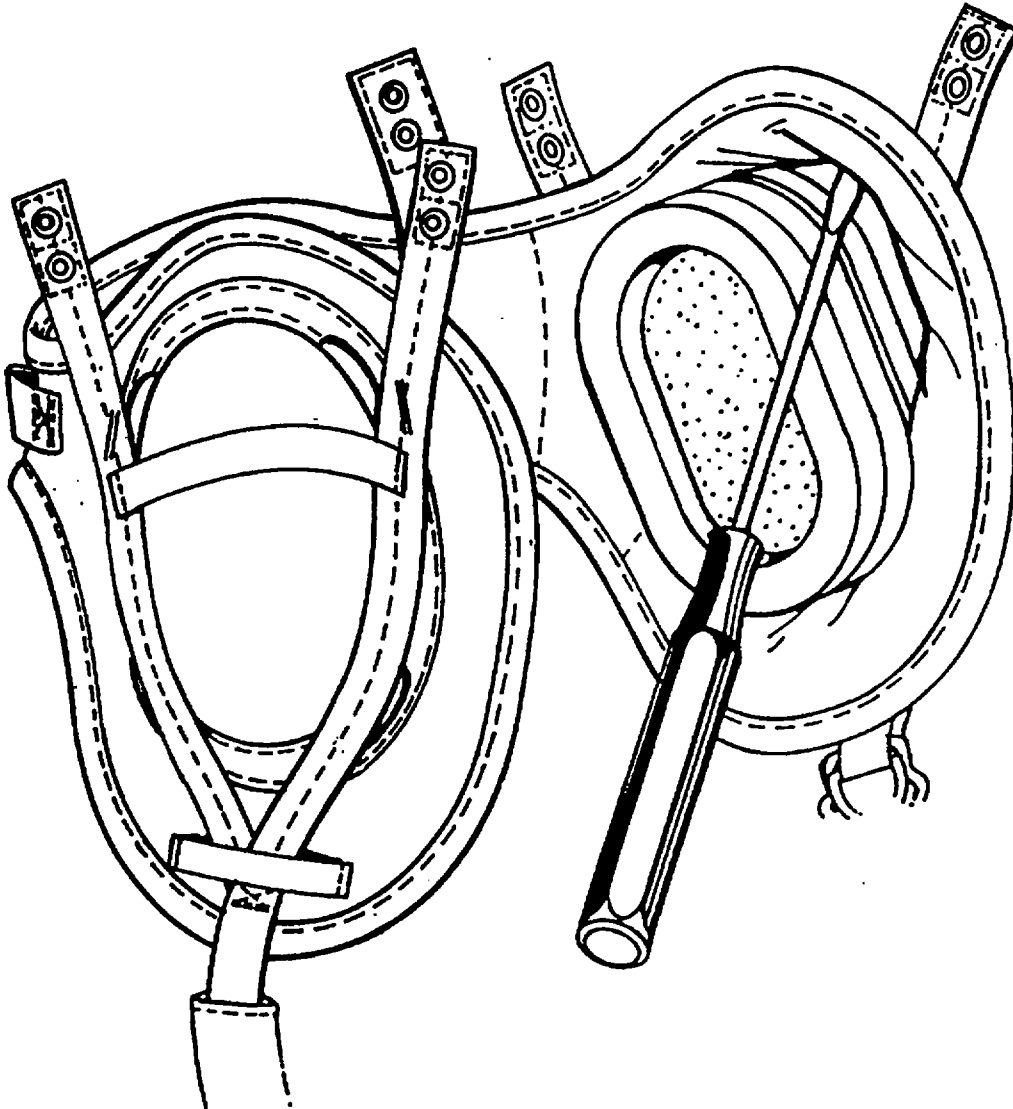

Figure 3-7. Removal of Earcup

**Installation****NOTE**

Be sure to install the left earcup assembly on the left side of the helmet (as worn and the right earcup on the right side). The flange of the left earcup assembly (hidden when the earseal is installed) is marked "TL" (top left); the flange of the right earcup assembly is marked "TR" (top right). Ensure that the earpad is installed; lift the inner edge of the earpad at either end of the earcup until you locate the "TL" or "TR" mark on the flange. The "TL" or "TR" mark should be positioned toward the top of the helmet when the earcup is installed.

**CAUTION**

- Do not bend earcup flange excessively; flange may break.
- When installing earcup into retention, be careful not to tear retention with screwdriver or awl.

1. Install and secure earpad as follows: Locate the rim on the underside of the earpad. Place either end of this rim over the earcup tab closest to the "TL" or "TR" mark on the earcup flange. Working from that end, stretch the remainder of the rim over the flange, leaving the remaining earcup tabs exposed. When the entire rim is stretched over the flange, remove the end of the rim from the earcup tab.

2. Moving retention "V" strap aside, position replacement earcup into retention assembly so that retention is between raised earcup tabs.

3. Working around edge of earcup, carefully use screwdriver or awl to lift retention over earcup tabs. Position retention so that the four corner earcup tabs are visible on outside of retention (See Figure 3-8).

4. Insert communications cord and rubber grommet into hole at rear of replacement earcup. If necessary, CAREFULLY use screwdriver to work grommet securely into hole.

5. Insert 1/4-inch filler pad into earcup, leaving communications cord leads exposed.

6. Attach communications cord leads to earphone using small flat-tip screwdriver or hex key as desired.

**NOTE**

When performing Step 7, ensure earphone speaker holes will face ear when helmet is worn.

7. Insert earphone into earphone holder, and insert both into earcup.

8. Reposition "V" strap through loop of retention.

9. Repeat procedure for other earcup.

10. Have crewmember don helmet; verify helmet fit.

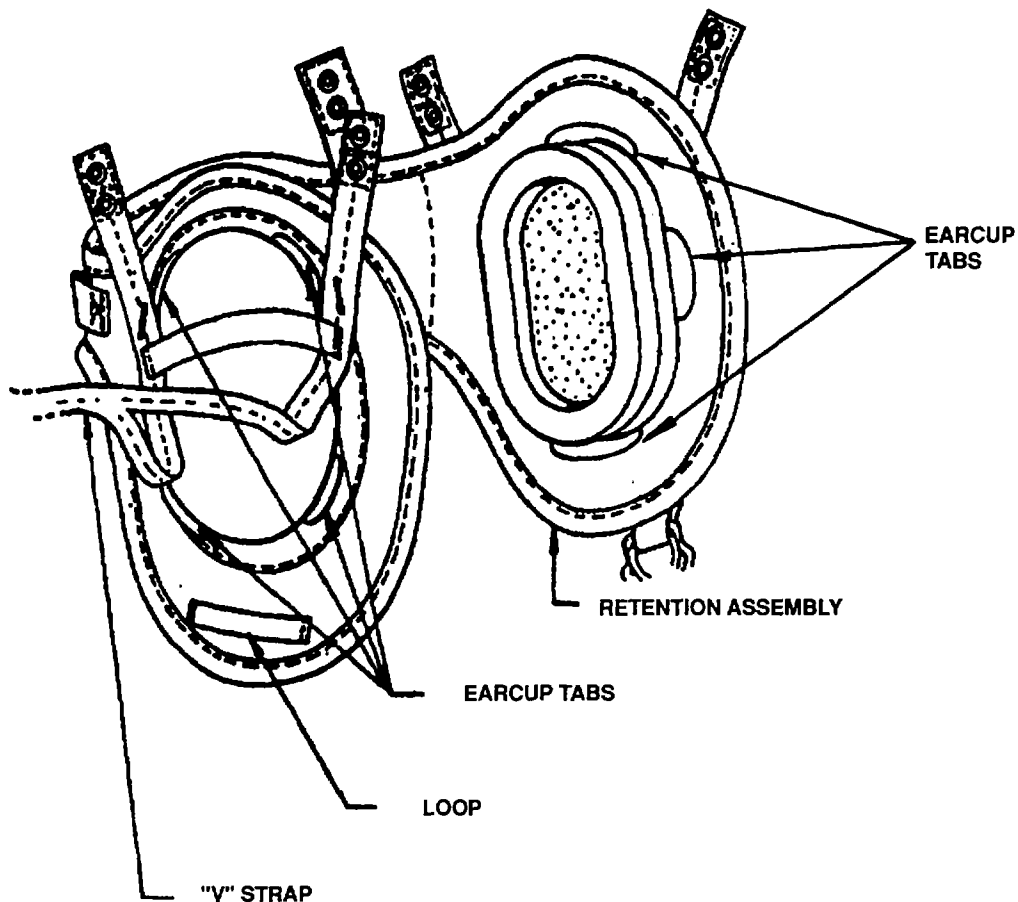

Figure 3-8. Replacement Earcups Installed

**3-9. Earcup Spacer Pads.**

**Installation**

**NOTES**

Install earcup spacer pads only if further fitting is required after cross straps have been adjusted.

Steps 2 and 3 are not required if pressure-sensitive pile exists on back of earcups.

Spacer pads can be cut to any shape shown in Figure 3-9 to balance earcup compression as needed.

Use trial-and-error method when adding or trimming earcup spacer pads. Goal is to achieve optimum noise reduction and most comfortable fit.

1. If necessary, trim pads to applicable shape.
2. Peel backing from adhesive side of pad.
3. Press adhesive side of pad against back of earcup.

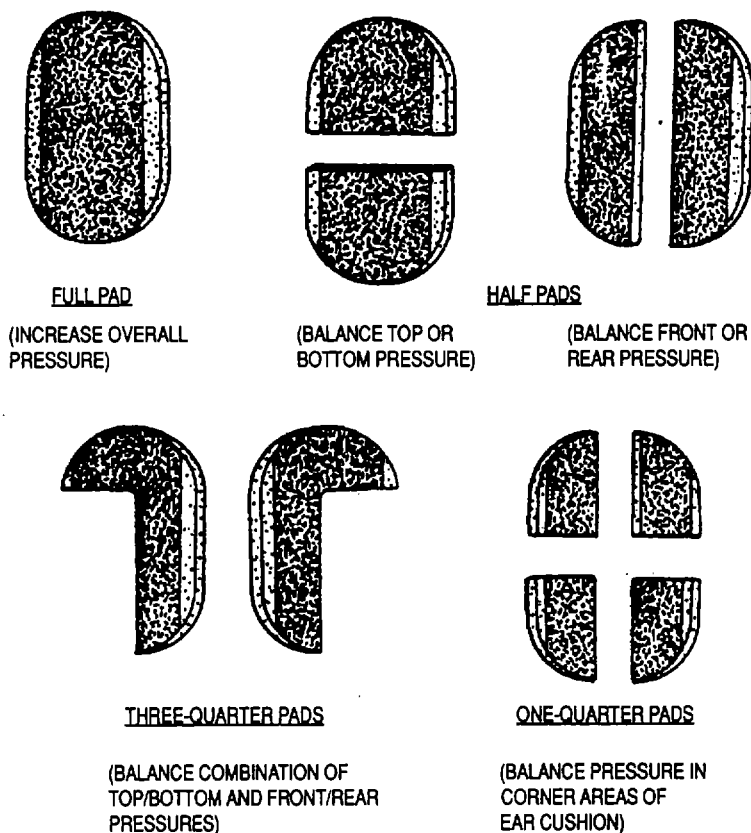

**Figure 3-9. Spacer Pad Applications**

**3-10. Microphone/Boom/Swivel Assembly.**

**INITIAL SETUP TABLE**

TOOLS	MATERIALS/PARTS	PERSONNEL REQUIRED
<ul style="list-style-type: none"> <li>General Aircraft Mechanics Tool Kit</li> </ul>		A.L.S.E. Specialist/Technician or Personnel with ASI of H2/Q2 (ALSE Qualified)
<ul style="list-style-type: none"> <li>Razor blade/knife/ small scissors</li> </ul>		
<ul style="list-style-type: none"> <li>Heat Gun</li> </ul>		

**Removal**

1. Unplug microphone cord from connector at rear of helmet.
2. Remove center screw (inside) attaching swivel assembly to helmet. Lift microphone, swivel assembly, boom and microphone cord away from helmet.

**Replacement**

1. Attach microphone/boom/swivel assembly to helmet with center screw. See illustration below.
2. Plug microphone cord into connector at rear of helmet.

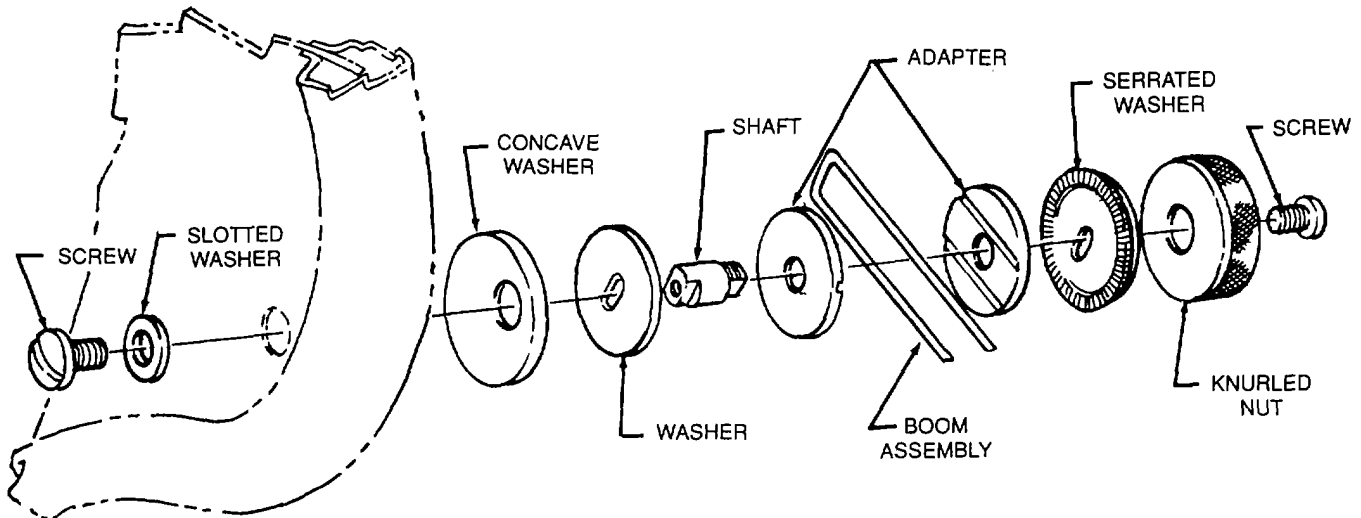



### 3-11. Communications Cord.

#### Removal

1. Unplug microphone cord from connector at rear of helmet.
2. Remove two screws securing jack plate and mounting plate to helmet shell.
3. Remove thermoplastic liner and energy-absorbing liner per paragraph 3-5, removal steps 1-3.
4. Remove screw, washer, and post securing cord strain relief from left rear of helmet (see Figure 3-10).
5. Remove earphones per paragraph 3-8, removal step 2.
6. Remove grommet from helmet shell, and remove communications cord from helmet (pull from inside out).

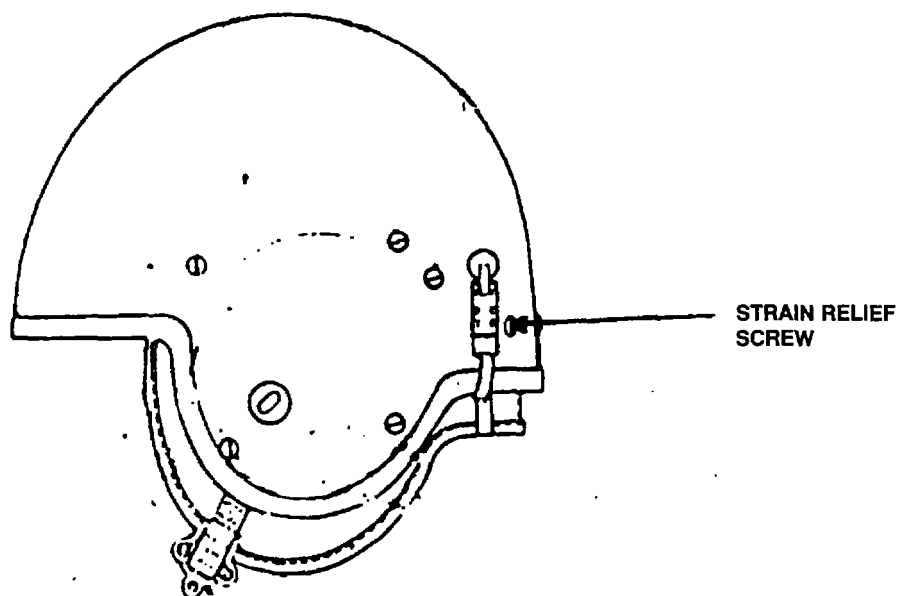

Figure 3-10. Location of Communications Cord Strain Relief

## Installation

1. Insert replacement cord through grommet hole in shell and attach grommet to helmet shell.
2. Secure cord in strain relief and attach strain relief to helmet shell using screw, washer and post removed in step 4.
3. Secure jack plate and mounting plate to helmet shell using screws removed in step 2, removal.
4. Install thermoplastic liner and energy-absorbing liners per paragraph 3-5, replacement steps 1-3.
5. Feed cord through earcups and attach grommet to earcup.
6. Attach cord leads to earphone, insert earphone into earphone holder, and place both in earcup.
7. Insert microphone cord plug into connector.

3-12. Dual Visor Assembly.

INITIAL SETUP TABLE

TOOLS	MATERIALS/PARTS	PERSONNEL REQUIRED
<ul style="list-style-type: none"> <li>General Aircraft Mechanics Tool Kit</li> </ul>		A.L.S.E. Specialist/Technician or Personnel with ASI of H2/Q2 (ALSE Qualified)

**NOTE**

Disregard removal steps 3 and 4 if nut plates are installed in your helmet.

1. Remove four screws attaching existing visor assembly to helmet shell.
2. Ensure that moleskin guards have been installed on underside of visor housing as shown in Figure 3-11.
3. Remove thermoplastic liner and energy-absorbing liner from helmet per paragraph 3-5, removal steps 1-3.
4. Remove four posts that were secured to visor housing screws.

**NOTE**

If ANVIS NVG attachment is to be used, ANVIS mount must be installed on visor housing before visor assembly can be assembled and installed. Proceed to paragraph 3-15 and complete the steps for installing the ANVIS mount. Then return to this procedure.

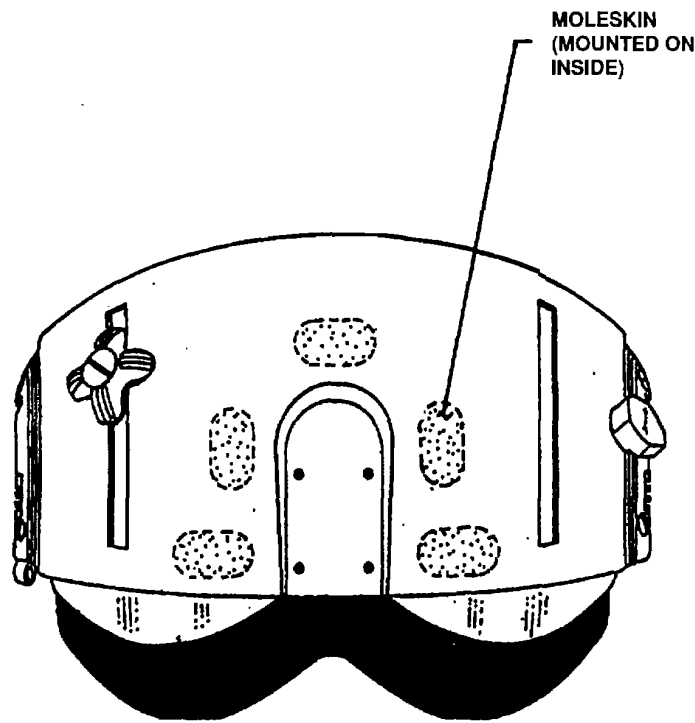

Figure 3-11. Dual visor Assembly

NOTES

- Be sure to install spacers and tracks on the side of the housing (right or left) for which they were configured. When installed correctly, these parts will curve toward the center of the visor housing (see Figure 3-12.)
- Some visor assemblies include nut plates to be installed between the posts and the underside of the helmet shell to hold the posts in place. Steps 2 and 3 on the next page describe the installation of the nut plate. The flat side of the nut plate (the side without the prongs) must be installed facing the visor housing. Either edge of the nut plate - the straight edge or the slotted edge - may face outward; in Figure 3-12, the straight edge is shown facing outward.
- Spacer, tracks, screws, posts, and nut plate are shown only on the left side of the visor housing in Figure 3-12. A similar configuration exists for the right side.

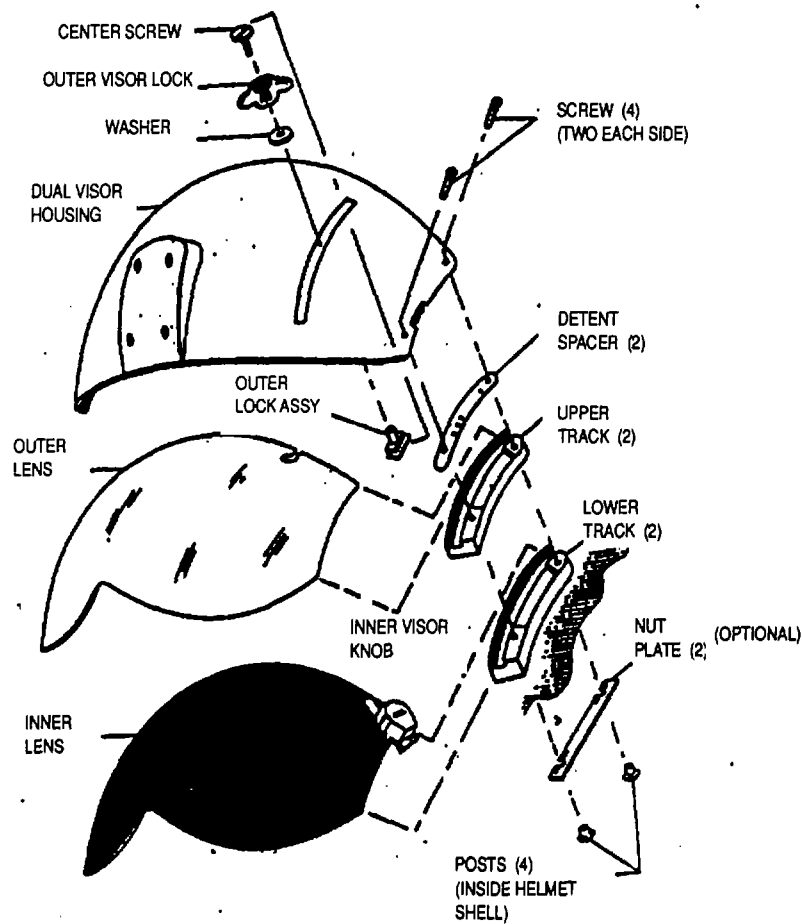

Figure 3-12. Dual Visor Assembly (Exposed View)

**NOTE**

Refer to Figure 3-12 and Figure C-2.

1. On right side (as worn) of visor housing, insert a replacement screw through each of the two holes. Place right-hand detent spacer on screws against underside of housing, followed by right-hand upper track (thin) and right-hand lower track (thick) in that order. Set housing aside with tracks and spacers facing upward so that parts stay together.

**NOTE**

If visor assembly does not include nut plates, it is recommended that you glue all four visor posts into the helmet shell with five-minute epoxy to prevent the posts from turning within the shell.

**CAUTION**

When completing step 2, ensure that 5-40 posts are used in nut plate; other sizes will not fit and may damage plate if forcing is attempted.

2. Bend nut plate slightly to lift prongs. Slide post into slot of nut plate so that prongs align with slot on head of post. Repeat for other post.

3. Position nut plate so that flat side faces underside of shell. Insert posts upward through track holes shell on right side of helmet (as worn).

4. Holding spacer and tracks against housing, position them over posts. Tighten screws into posts for a snug (but not tight) hold.

5. On left side (as worn) of visor housing, insert replacement screws through holes. Lift left side of visor housing just enough to allow room to place left-hand detent spacer and left-hand upper and lower tracks on screws. Holding spacer and tracks against housing as in previous step, position them over track holes on left side of helmet shell. Insert posts through nut plate and through underside of helmet shell (on left side as worn) as in steps 2 and 3. Tighten screws into posts.

6. Slide outer (clear) lens into upper tracks. Insert visor key through housing slot (on either side as desired) and into cutout in visor; push lock assembly down and rotate a quarter turn counterclockwise to lock into place. Place washer and visor lock over-visor lock assembly; install and tighten center screw of visor lock. Center screw has a left-hand thread.

7. Remove right or left front screw as desired. Use screw to lift upper track just enough to provide clearance for inner visor knob. Slide inner (neutral grey) visor into lower tracks.

8. Realign left (or right, as applicable) front tracks and spacer over post. Insert screw and tighten securely.

9. Tighten remaining three screws securely.

10. Test outer visor operation by using outer visor lock. Test inner visor operation by using inner visor knob. If either visor does not move freely, loosen screws, hold visor housing at sides, move housing side to side as required, and re-tighten screws.

11. To move the outer visor lock from one side to the other, follow these steps:

(a) Move inner (neutral grey) visor down about halfway.

(b) Disassemble outer visor lock and remove key.

(c) Move visor key to cutout on other side of visor and install as in step 6. Assemble visor lock, washer, and center screw as in step 6. Test visor for proper operation.

12. To move the inner visor knob from one side to the other, follow these steps:

(a) Remove front screw on the side where the visor knob is located.

(b) Loosen all visor housing screws.

(c) Lifting upper track slightly, remove visor.

(d) Remove screws and posts attaching knob to visor; move knob to holes on other side of visor and reattach screws and posts.

(e) Remove front screw on other side; lift upper track slightly and reinsert visor into lower track. Realign front of visor assembly and reinstall front screws. Tighten all screws securely. Test visors for proper operation.

**3-13. Outer Visor Lock.**

**INITIAL SETUP TABLE**

TOOLS	MATERIALS/PARTS	PERSONNEL REQUIRED
<ul style="list-style-type: none"> <li>General Aircraft Mechanics Tool Kit</li> </ul>	NONE	A.L.S.E. Specialist/Technician or Personnel with ASI of H2/Q2 (ALSE Qualified)

**Removal**

1. Move inner (neutral grey) visor down about halfway.
2. Disassemble outer visor lock by removing center screw (left hand thread), lock key and washer.

**NOTE**

Push key down and rotate 1/4 turn to remove.

**Installation**

1. Insert visor key through housing slot (on either side as desired) and into cutout in visor; push key down and rotate a quarter turn counterclockwise to lock into place.
2. Place washer and visor lock over visor key; install and tighten center screw of visor lock. Center screw has a left-hand thread.
3. Test visor for proper operation.

**3-14. Inner Visor Knob.**

**INITIAL SETUP TABLE**

TOOLS	MATERIALS/PARTS	PERSONNEL REQUIRED
General Aircraft Mechanics Tool Kit	NONE	A.L.S.E. Specialist/Technician or Personnel with ASI of H2/Q2 (ALSE Qualified)

**NOTE**

If this helmet is not equipped with nut plates (see paragraph 1-3), refer to paragraph 3-6 and remove TPL.

**Removal**

1. Remove front screw on the side where the visor knob is located.
2. Loosen all remaining visor housing screws.
3. Lifting upper track slightly, remove visor.
4. Remove screws and posts attaching knob to visor.

**Installation**

1. Install knob using screws and posts previously removed.
2. Lift upper track slightly and reinsert visor into lower track. Reinstall front screw; tighten all screws securely.
3. Test visor for proper operation.
4. If TPL was removed, install per paragraph 3-6.



**3-15. ANVIS Mount Installation.**

**INITIAL SETUP TABLE**

TOOLS	MATERIALS/PARTS	PERSONNEL REQUIRED
<ul style="list-style-type: none"> <li>• General Aircraft Mechanics Tool Kit</li> </ul>	ANVIS Attachment Kit	A.L.S.E. Specialist/Technician or Personnel with ASI of H2/Q2 (ALSE Qualified)

**NOTE**

Before the ANVIS NVG can be installed on the SPH-4B, the ANVIS mount and a cable clip must be attached. The ANVIS attachment kit contains installation instructions, four screws for the rear of the mount, a cable clip and attaching screw, pile fastener for ANVIS battery pack attachment, and a moleskin lens guard for visor protection. Install the ANVIS mount as follows:

1. Remove outer visor lock from dual visor assembly by removing center screw, lock-key and washer. Set aside for reinstallation.
2. Loosen all remaining visor housing screws.
3. Remove top two screws from dual visor assembly, lift housing from tracks, and reinstall screws beneath housing into tracks. Repeat procedure for bottom visor assembly screws, and remove housing from helmet. This will ensure that the visor assembly remains intact during ANVIS mount installation.
4. Remove and discard four screws from rear of ANVIS mount. Place mount against dual visor housing and align mount holes with visor housing holes. Secure mount to housing by inserting four 3/16" pan-head screws (supplied) through housing and into mount. Fasten screws securely, but do not overtighten.
5. Attach moleskin lens guard to inside bottom of visor housing at center of ANVIS mount area.
6. Place housing on visor assembly and attach to helmet using four screws.
7. Position cable clip on right side (as worn) of visor housing and secure using 5/16" screw supplied. Insert screw through clip and into insert on bottom of right-side visor track. Feed cable through clip and tighten screw securely, but do not overtighten.
8. Install outer visor knob using center screw, lock, and washer removed in step 1.
9. Attach pressure-sensitive pile fastener to center rear of helmet for ANVIS battery pack.

**3-16. ANVIS Goggles (attachment).**

With the ANVIS dual visor assembly installed on the helmet, attach the ANVIS goggles as follows:

1. Attach the power pack to the helmet using the hook-and-pile fastener already installed on the helmet.
2. Connect the ANVIS mount cable connector to the power pack cable connector.
3. Attach ANVIS goggles to ANVIS mount and place in desired position (stowed or deployed).

### 3-17. Cross Straps. INITIAL SETUP TABLE

TOOLS	MATERIALS/PARTS	PERSONNEL REQUIRED
<ul style="list-style-type: none"> <li>General Aircraft Mechanics Tool Kit</li> </ul>	NONE	A.L.S.E. Specialist/Technician or Personnel with ASI of H2/Q2 (ALSE Qualified)

#### Removal (Figure 3-13)

1. Unhook cross strap from adapter (1).
2. Remove post and front retention strap.
3. Remove screw, washer, and adapter.
4. Remove screw, washer and post securing other end of cross strap (2) to helmet, and remove cross strap.
5. As necessary, remove other cross straps in same manner.

#### Installation (Figure 3-13)

1. Position adapter against helmet shell, and install with screw and washer; install front retention strap and post.
2. Secure non-hook end of cross strap (2) to helmet with screw, washer and post.
3. Hook other end of cross strap (1) into adapter.
4. As necessary, install other cross straps in same manner.

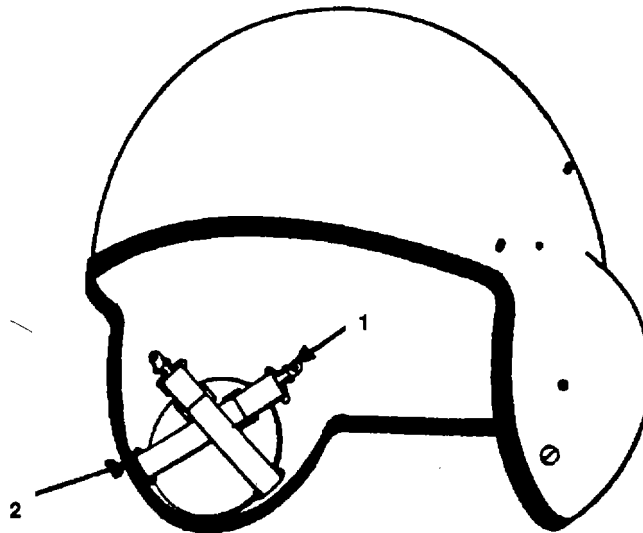

Figure 3-13. Cross Straps

**3-18. Chafing Pad.**

**INITIAL SETUP TABLE**

TOOLS	MATERIALS/PARTS	PERSONNEL REQUIRED
<ul style="list-style-type: none"> <li>General Aircraft Mechanics Tool Kit</li> </ul>	Cloth	A.L.S.E. Specialist/Technician or Personnel with ASI of H2/Q2 (ALSE Qualified)

**Removal (Figure 3-14)**

1. Unhook cross straps from adapters.
2. Peel worn chafing pad away from helmet shell.
3. Rub off old adhesive with clean cloth.

**Replacement (Figure 3-14)**

1. Apply synthetic rubber adhesive to helmet where old adhesive was removed.
2. Install new chafing pad over adhesive.
3. Hook cross straps to adapters.

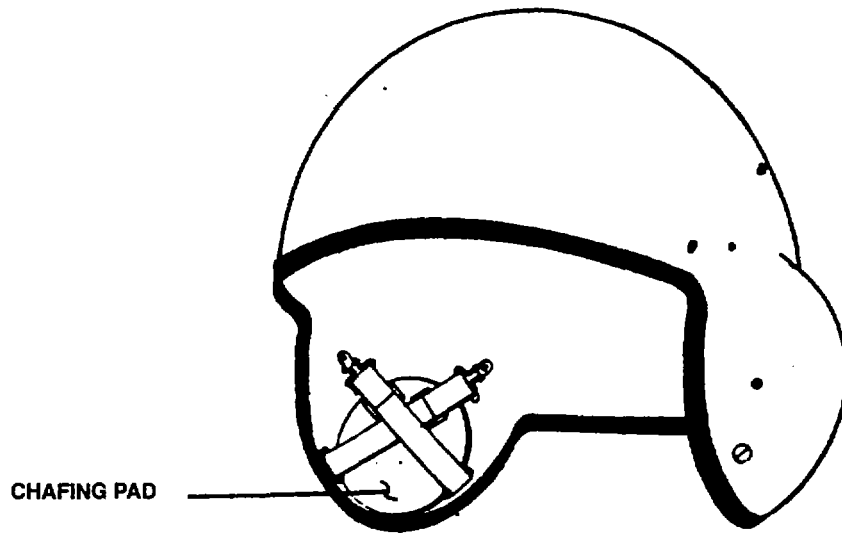

**Figure 3-14. Chafing Pad**

**3-19. Edge Beading.**

**INITIAL SETUP TABLE**

<b>TOOLS</b>	<b>MATERIALS/PARTS</b>	<b>PERSONNEL REQUIRED</b>
<ul style="list-style-type: none"> <li>• Razor Blades</li> <li>• Rubber Adhesive</li> </ul>	<ul style="list-style-type: none"> <li>• Cloth</li> <li>• Edge Beading</li> </ul>	<ul style="list-style-type: none"> <li>• A.L.S.E. Specialist/Technician or Personnel with ASI of H2/Q2 (ALSE Qualified)</li> </ul>
<ul style="list-style-type: none"> <li>• Scissors</li> </ul>		

**NOTE**

Edge beading is already installed on the helmet shell. The sole purpose of this task is to replace worn edge beading.

**Replacement**

1. Peel worn edge beading away from helmet.
2. Rub off old adhesive with clean cloth. Use razor blade, if necessary.
3. Coat helmet edge and edge beading with synthetic rubber adhesive.
4. Install beading evenly over adhesive. Allow to dry. Cut off excess edge beading with scissors.
5. Rub off any excess adhesive with clean cloth.

**3-20. Touch-up Painting.**

**INITIAL SETUP TABLE**

TOOLS	MATERIALS/PARTS	PERSONNEL REQUIRED
<ul style="list-style-type: none"> <li>Brush Appendix D</li> </ul>	Polyurethane, item 2	A.L.S.E. Specialist/Technician or Personnel with ASI of H2/02 (ALSE Qualified)

**NOTE**

The purpose of this procedure is to paint the helmet shell and/or dual visor housing to cover paint blemishes.

1. Place helmet shell or visor housing on stand.
2. Paint helmet with Polyurethane MIL-C-46168 (Item 2, App D) O.D. #34088.
3. Allow to air-dry for 72 hours.

APPENDIX A

REFERENCES

**A-1. Dictionaries of Terms and Abbreviations.**

- AR 310-25 ..... Dictionary of United States Army Terms
- AR 310-50 ..... Authorized Abbreviations and Brevity Codes

**A-2. Publication Index.**

- DA PAM 25-30 ..... Consolidated Index of Army Publications and Blank Forms

**A-3. Logistics and Storage.**

- TM 1-1500-204-23 (Series) ..... General Aircraft Maintenance Manual
- TM 43-200-1 ..... Storage and Materials Handling

**A-4. Maintenance of Supplies and Equipment.**

- AR 750-1 ..... Army Material Maintenance Concepts and Policies
- TM 743-0139 ..... Painting Operations Instructions for Field Use

**A-5. Other Publications.**

- AR 420-90 ..... Fire Protection and Prevention
- AR 55-38 ..... Reporting of Transportation Discrepancies in Shipments
- AR 700-58 ..... Packaging Improvement Report
- DA PAM 738-751 ..... Functional Users Manual for Army Maintenance Management System  
Aviation (TAMMS-A)
- FM 21 -11 ..... First Aid for Soldiers
- TM 750-244-1-4 ..... Procedures for the Destruction of Aviation Ground Support Equipment  
(FSC 8415) to Prevent Enemy Use
- TM 3-4240-312-23&P ..... M43 2 Mask
- TM 3-4240-334-10 ..... Operator M43-A1 Mask
- TM 3-4240-334-20&P ..... Maintenance and Parts, M43-A1 Mask
- TM 11-5855-263-10 ..... Aviator's Night Vision Imaging System, AN-PVS-6
- TM 11 -5965-279-13&P ..... Headset-Microphone MK-896A/A/C

☆U.S. GOVERNMENT PRINTING OFFICE: 1995 0 - 388-421 (02483)

## APPENDIX B

MAINTENANCE ALLOCATION CHART

---

## Section I. INTRODUCTION

**B-1. General.**

a. This section provides a general explanation of all maintenance repair functions authorized at various maintenance categories.

b. The Maintenance Allocation Chart (MAC) in Section II designates overall authority and responsibility for the performance of maintenance functions on the identified end item or component. The application of maintenance functions to the end item or component will be consistent with the capacities and capabilities of the designated maintenance categories.

c. Section III lists the tools and test equipment (both special tools and common tool sets) required for each maintenance function as referenced from Section II.

d. Section IV contains supplemental instructions and explanatory notes for a particular maintenance function.

**B-2. Maintenance Functions.** Maintenance functions will be limited to and defined as follows:

a. Inspect. To determine the serviceability of an item by comparing its physical, mechanical and/or electrical characteristics with established standards through examination (e.g., by sight, sound, or feel).

b. Test. To verify serviceability by measuring the mechanical, pneumatic, hydraulic, or electrical characteristics of an item and comparing those characteristics with prescribed standards.

c. Service. Operations required periodically to keep an item in proper operational condition, i.e., to clean (includes decontaminate, when required), to preserve, to drain, to paint, or to replenish fuel, lubricants, hydraulic fluids, or gases.

d. Adjust. To maintain or regulate, within prescribed limits, by bringing into proper or exact position, or by setting the operating characteristics to the specified parameters.

e. Aline. To adjust specified variable elements of an item to bring about optimum or desired performance.

f. Calibrate. To determine and cause corrections to be made or to be adjusted on instruments or test measuring and diagnostic equipments used in precision measurement. Consists of comparisons of two instruments, one of which is a certified standard of known accuracy, to detect and adjust any discrepancy in the accuracy of the instrument being compared.

g. Remove/install. To remove and install the same item when required to perform service or other maintenance functions. Install may be the act of emplacing, seating, or fixing into position a spare, repair part, or module (component or assembly) in a manner to allow the proper functioning of an equipment or system.



h. Replace. To remove an unserviceable item and install a serviceable counterpart in its place. "Replace" is authorized by the MAC and is shown as the d position code of the SMR code.

i. Repair. The application of maintenance services including fault location/troubleshooting, removal/installation, and disassembly/assembly procedures, and maintenance actions to identify troubles and restore serviceability to an item by correcting specific damage, fault, malfunction, or failure in a part, subassembly, module (component or assembly), end item, or system.

j. Overhaul. The maintenance effort (service/action) prescribed to restore an item to a completely serviceable/operational condition as required by maintenance standards in appropriate technical publications (i.e., DMWR). Overhaul is normally the highest degree of maintenance performed by the Army. Overhaul does not normally return an item to like new condition.

k. Rebuild. Consists of those service/actions necessary for the restoration of unserviceable equipment to a like new condition in accordance with original manufacturing standards. Rebuild is the highest degree of material maintenance applied to Army equipment. The rebuild operation includes the act or returning to zero those age measurements (hours, miles, etc.) considered in classifying Army equipments/components.

**B-3. Explanation of Columns in the MAC, Section II.**

a. Column 1, Group Number. Column 1 lists functional group code numbers, the purpose of which is to identify maintenance significant components, assemblies, subassemblies, and modules with the next higher assembly. End item group number shall be "00."

b. Column 2, Component/Assembly. Column 2 contains the names of components, assemblies, subassemblies, and modules for which maintenance is authorized.

c. Column 3, Maintenance Function. Column 3 lists the functions to be performed on the item listed in Column 2. (For detailed explanation of these functions, see paragraph B-2.)

d. Column 4, Maintenance Category. Column 4 specifies, by the listing of a work time figure in the appropriate subcolumn(s), the category of maintenance authorized to perform the function listed in Column 3. This figure represents the active time required to perform that maintenance function at the indicated category of maintenance. If the number or complexity of the tasks within the listed maintenance function vary at different maintenance categories, appropriate work time figures will be shown for each category. The work time figure represents the average time required to restore an item (assembly, subassembly, component, module, end item, or system) to a serviceable condition under typical field operating conditions. This time includes preparation time (including any necessary disassembly/assembly time), troubleshooting/fault location time, and quality assurance/quality control time in addition to the time required to perform the specific tasks identified for the maintenance functions authorized in the maintenance allocation chart. The symbol designations for the various maintenance categories are as follows:

AVUM	Aviation Unit Maintenance
AVIM	Aviation Intermediate Maintenance
DEPOT	Depot Maintenance

e. Column 5, Tools and Equipment. Column 5 specifies, by code, those common tool sets (not individual tools) and special tools, TMDE, and support equipment required to perform the designated function.

- f. Column 6, Remarks. This column shall, when applicable, contain a letter code, in alphabetic order, which shall be keyed to the remarks contained in Section IV.

**B-4. Explanation of Columns in Tool and Test Equipment Requirements, Section III.**

- a. Column 1, Reference Code. The tool and test equipment reference code correlates with a code used in the MAC, Section II, Column 5.
- b. Column 2, Maintenance Category. The lowest category of maintenance authorized to use the tool or test equipment.
- c. Column 3, Nomenclature. Name or identification of the tool or test equipment.
- d. Column 4, National Stock Number. The national stock number of the tool or test equipment.
- e. Column 5, Tool Number. The manufacturer's part number.

**B-5. Explanation of Columns in Remarks, Section IV.**

- a. Column 1, Reference Code. The code recorded in column 6, Section II.
- b. Column 2, Remarks. This column lists information pertinent to the maintenance function being performed as indicated in the MAC, Section II.

Section II. MAINTENANCE ALLOCATION CHART

(1) GROUP NUMBER	(2) COMPONENT/ASSEMBLY	(3) MAINTENANCE FUNCTION	(4) MAINTENANCE CATEGORY			(5) TOOLS & EQPT	(6) REMARKS
			AVUM	AVIM	DEPOT		
01	Helmet Assembly						
0101	Helmet	Inspect Service Repair	-●-	-●-	-●-	14	
0102	Pad, Earcup Chafing	Inspect Replace	-●-	-●-		1, 2, 3, 4, 11	
0103	Earcup Cross Strap	Inspect Adjust Replace	-●-	-●-	-●-	1, 2, 3, 15	A
0104	Beading	Inspect Replace	-●-	-●-		8, 13	
02	Dual Visor Assembly						
0201	Guard Lock Assembly	Inspect Adjust Replace	-●-	-●-	-●-	1, 2, 3, 6, 7, 15	A
0202	Visor Housing	Inspect Service Replace	-●-	-●-	-●-	1, 2, 3, 6, 7, 15	A
0203	Visor Tracks and Spacers	Inspect Replace	-●-	-●-		1, 2, 3, 6, 7, 15	A
0204	Visor	Inspect Service Replace	-●-	-●-	-●-	1, 2, 3	
03	Liner Assembly						
0301	Liner, Energy Absorbing	Inspect Replace	-●-	-●-		1, 6, 7	
0302	Liner, Thermoplastic	Inspect Replace	-●-	-●-		1	

MAINTENANCE ALLOCATION CHART (Continued)

(1)	(2)	(3)	(4) MAINTENANCE CATEGORY			(5) TOOLS & EQPT	(6)
GROUP NUMBER	COMPONENT/ASSEMBLY	MAINTENANCE FUNCTION	AVUM	AVIM	DEPOT		REMARKS
04	Retention Assembly						
0401	Retention Assembly/ Chinstrap	Inspect Adjust Replace	--	--	--	1, 9, 2, 3, 5, 11, 15	
05	Earcup Assembly						
0501	Seal	Inspect Replace	--	--			
0502	Cushion Insert	Inspect Replace	--	--		1	
0503	Earcup	Inspect Replace	--	--		1, 9, 2, 3, 5, 10, 11	
0504	Cushion Backing	Inspect Replace	--	--			
06	Microphone						
0601	Headset-Microphone Kit						B

**Section III. SPECIAL TOOL AND TEST EQUIPMENT REQUIREMENTS**

<b>REFERENCE CODE</b>	<b>MAINTENANCE CATEGORY</b>	<b>NOMENCLATURE</b>	<b>NATIONAL/NATO STOCK NUMBER</b>	<b>TOOL NUMBER</b>
1	0	Mechanics Tool Box	5180-00-323-4692	
2	0	Screwdriver, Flat Tip	5120-00-222-8852	
3	0	Screwdriver 1/8 inch Blade	5120-00-236-2140	
4	0	Screwdriver, Jewellers	5120-00-288-8739	
5	0	Screwdriver 1/4 inch Blade	5120-00-596-8502	
6	0	Tongue Depressor	6515-00-509-8872	
7	0	Spatula, 8 inch Blade	7330-00-254-4791	
8	0	Razor Blade	8530-00-162-5629	
9	0	Scissors	5110-00-293-9199	
10	0	Hex Key .035	5120-00-198-5400	
11	0	Awl	5120-00-221-1542	
12	0	Soldering Gun	3439-00-004-0915	
13	0	Knife, Craftsman	5110-00-595-8400	
14	0	Brush, Paint	8020-00-297-6657	
15	0	Screwdriver, Flat Tip Special (See Figure B-1)		

Section IV. REMARKS

(1) REFERENCE CODE	(2) REMARKS
A	See Figure B-1 for Modified Screwdriver
B	See TM 11-5965-279-13&P

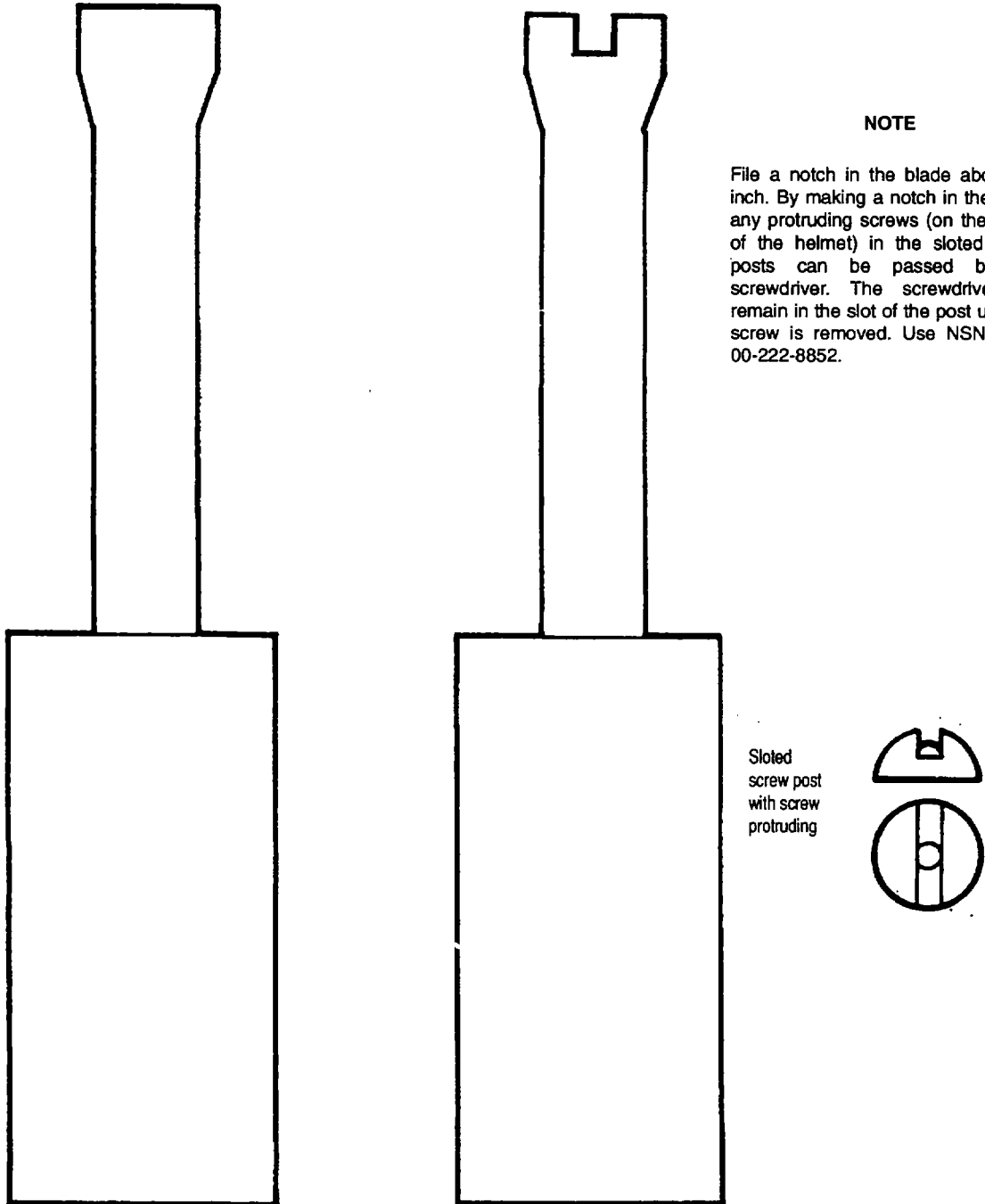

Figure B-1. Special Tool, Modified Screwdriver

## APPENDIX C

REPAIR PARTS AND SPECIAL TOOLS LIST

---

## Section I. INTRODUCTION

**1. Scope.** This RPSTL lists and authorizes spares and repair parts; special test, measurement, and diagnostic equipment (TMDE); and other special support equipment required for performance of AVUM maintenance of the helmet. It authorizes the requisitioning, issue, and disposition of spares, repair parts and special tools as indicated by the source recoverability (SMR) codes.

**2. General.** In addition to Section I, Introduction, this Repair Parts and Special Tools List is divided into the following sections:

a. Section II. Repair Parts List. A list of spares and repair parts authorized by this RPSTL for use in the performance of maintenance. The list also includes parts which must be removed for replacement of the authorized parts. Parts lists are composed of functional groups in ascending alphanumeric sequence, with the parts in each group listed in ascending figure and item number sequence. Repair parts kits are listed separately in their functional group within Section II. Repair parts for repairable special tools are also listed in this section. Items listed are shown on the associated illustration(s)/figure(s).

b. Section III. Special Tools List. A list of special tools, special TMDE, and other special support equipment authorized by this RPSTL (as indicated by Basis of Issue (BOI) information in DESCRIPTION AND USABLE ON CODE column) for the performance of maintenance.

c. Section IV. National Stock Number and Part Number Index. A list, in National Item identification number (NIIN) sequence, of all National stock numbered items appearing in the listing, followed by a list in alphanumeric sequence of all part numbers appearing in the listings. National stock numbers and part numbers are cross-referenced to each illustration figure and item number appearance.

**3. Explanation of Columns (Sections II and III).**

a. ITEM NO. (Column 1). Indicates the number used to identify items called out in the illustration.



b. SMR CODE. (Column 2). The Source, Maintenance, and Recoverability (SMR) code is a 5-position code containing supply/requisitioning information, maintenance category authorization criteria, and disposition instruction, as shown in the following breakout:

Source Code	Maintenance Code		Recoverability Code
v	v		v
____1 st two x positions	xx		x
v	v	v	v
How you get an item	3rd position  Who can install, replace or use the item	4th position  Who can do complete repair* of the item	Who determined disposition action on an unservicable item

\*Complete Repair: Maintenance capacity, capability, and authority to perform all corrective maintenance tasks of the "Repair" function in a use/user environment in order to restore serviceability to a failed item.

(1) Source Code. The source code tells you how to get an item needed for maintenance, repair, or overhaul of an end item/equipment. Explanations of source codes follows:

Code	Explanation
PA PB PC PD PE PF PG	Stocked items; use the applicable NSN to request/requisition items with these source codes. They are authorized to the category indicated by the code entered in the 3rd position of the SMR code.  **Note: Items coded PC are subject to deterioration.
KD KF KB	Items with these codes are not to be requested/requisitioned individually. They are part of a kit which is authorized to the maintenance category indicated in the 3rd position of the SMR code. The complete kit must be requisitioned and applied.

**GROUP 02. DUAL VISOR ASSEMBLY**

**Figure C-2. Dual Visor Assembly**

<b>ITEM NO.</b>	<b>SMR CODE</b>	<b>CAGEC</b>	<b>PART NUMBER</b>	<b>DESCRIPTION AND USABLE ON CODE (UOC)</b>	<b>QTY</b>
	PAOOO	97427	90C7930-12	DUAL VISOR ASSEMBLY (See fig C-1 for NHA)	REF
1	PAOZZ	97427	90D7931-12	.VISOR HOUSING	1
2	PAOZZ	97427	90D7932-2	.OUTER LENS, CLEAR	1
3	PAOZZ	97427	90D7933-3	.INNER LENS, NEUTRAL	1
4	XAOZZ	81337	8-2-523	.LOCK ASSY, VISOR	1
5	XAOZZ	97427	91B8089-10	.KNOB, INNER VISOR	1
6	PAOZZ	97427	90D7934-1	.LOWER TRACK, L/H	1
7	PAOZZ	97427	90C7935-1	.UPPER TRACK, L/H	1
8	PAOZZ	97427	90C8029-1	.DETENT SPACER, L/H	1
9	PAOZZ	97427	75A3096-49	.SCREW BLIND HEAD, 5-40 X 7/8 IN.	4
10	PAOZZ	81337	8-2-817	.POST, 5-40 X 5/16 IN.	4
11	PAOZZ	97427	90D7934-2	.LOWER TRACK, R/H	1
12	PAOZZ	97427	90C7935-2	.UPPER TRACK, R/H	1
13	PAOZZ	97427	90C8029-2	.DETENT SPACER, R/H	1
14	XDOZZ	97427	82A5653-1	.MOLESKIN LENS GUARD, CHARCOAL GREY	5
15	PAOZZ	97427	9 1B8 2 1 0	.NUT PLATE	2

END OF FIGURE

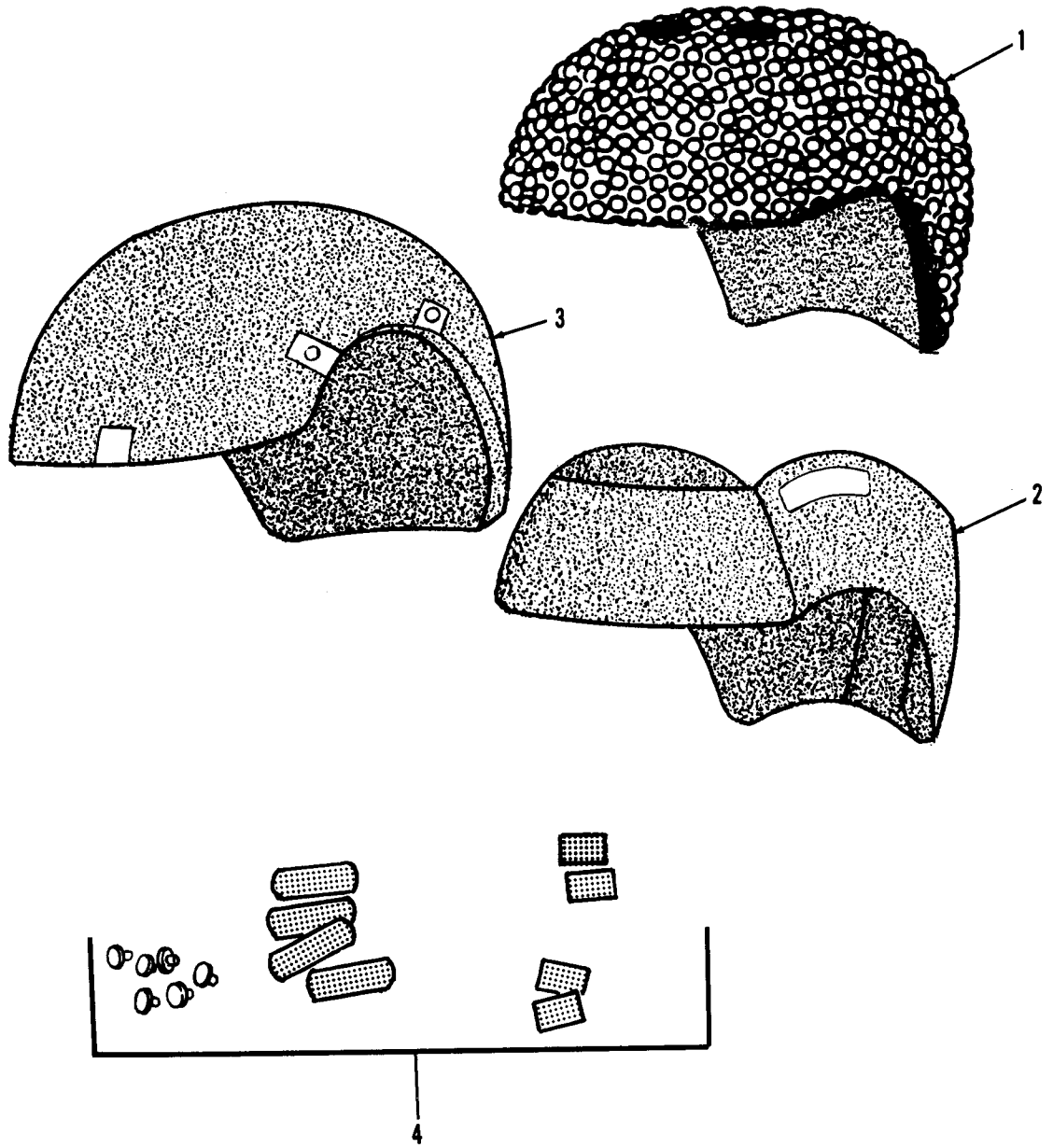

Figure C-3. Thermoplastic Liner Assembly

Code	Explanation
KO-(Made at org/ AVUM Level) MF-(Made at DS/ AVUM Level) ML-(Made at Spe- cialized Repair Act, SRA) MD-(Made at Depot)	Items with these codes are not to be requested/requisitioned individually. in the DESCRIPTION AND USABLE ON CODE (UOC) column and listed in the Bulk Material group of the repair parts list in the RPSTL. If the item is authorized to you by the third position code of the SMR code, but the source code indicates it is made at a higher level, order the item from the higher level of maintenance.
AO-(Assembled by org/AVUM level) AF-(Assembled by DS/AVIM Level) AH-(Assembled by GS Category) AL-(Assembled by SRA) AD-(Assembled by Depot)	Items with these codes are not to be requested/requisitioned individually. The parts that make up the assembled item must be requisitioned or fabricated and assembled at the level of maintenance indicated by the source code. If the 3rd position code of the SMR code authorizes you to replace the item, but the source code indicates the items is assembled at a higher level, order the item from the higher level of maintenance.
XA-	Do not requisition an "XA"-coded item. Order its next higher assembly. (Also, refer to the NOTE below).
XB-	If an "XB" item is not available for salvage, order it using the FSCM and part number given.
XC-	Installation drawing, diagram, instruction sheet, field service drawing, that is identified by a manufacturers part number.
XD-	Item is not stocked. Order an "XD"-coded item through normal supply channels using the FSCM and part number given if no NSN is available.

**NOTE**

Cannibalization or controlled exchange, when authorized may be used as a source of supply for items with the above source codes, except for those source coded "XA" or those aircraft support items restricted by requirements of AR 700-42.

(2) Maintenance Code. Maintenance codes tells you the level(s) of maintenance authorized to USE and REPAIR support items. The maintenance codes are entered in the third and fourth positions of the SMR Code as follows:

(a) The maintenance code entered in the third position tells you the lowest maintenance level authorized to remove, replace, and use an end item. The maintenance code entered in the third position will indicate authorization to one of the following levels of maintenance:

<b>Code</b>	<b>Application/Explanation</b>
C	-Crew or operator maintenance done within organization or aviation unit maintenance.
O	-Organizational or aviation unit category can remove, replace and use the item.
F	-Direct support or aviation intermediate level can remove, replace, and use the item.
H	-General support level can remove, replace, and use the item.
L	-Specialized repair activity can remove, replace, and use the item.
D	-Depot level can remove, replace, and use the item.

(b) The maintenance code entered in the fourth position tells whether or not the item is to be repaired and identifies the lowest maintenance level with the capability to do complete repair (i.e. perform all authorized repair functions).

**NOTE**

Some limited repair may be done on the item at a lower level of maintenance, if authorized by the Maintenance Allocation Chart (MAC) and SMR codes. This position will contain one of the following maintenance codes:

<b>Code</b>	<b>Application/Explanation</b>
O	- Organizational or aviation unit is the lowest level that can do complete repair of the item.
F	- Direct support or aviation intermediate is the lowest level that can do complete repair of the item.
H	- General support is the lowest level that can do complete repair of the item.
L	- Specialized repair activity (designate the specialized repair activity) is the lowest level that can do complete repair of the item.
D	- Depot is the lowest level that can do complete repair of the item.
Z	- Nonrepairable. No repair is authorized.
B	- No repair is authorized. (No parts or special tools are authorized for the maintenance of a "B" coded item). However, the item may be reconditioned by adjusting, lubricating, etc., at the user level.

(3) Recoverability Code. Recoverability codes are assigned to indicate the disposition action on unserviceable items. The recoverability code is entered in the fifty position of the SMR Code as follows:

Recoverability Codes	Application/Explanation
Z	- Nonrepairable item. When unserviceable, condemn and dispose of the item at the level of maintenance shown in 3rd position of SMR Code.
O	- Repairable item. When uneconomically repairable, condemn and dispose of the item at organizational or aviation unit level.
F	- Repairable item. When uneconomically repairable, condemn and dispose of the item at organizational or aviation unit level.
H	- Repairable item. When uneconomically repairable, condemn and dispose of the item at the general support level.
D	- Repairable item. When beyond lower level repair capability return to the depot. Condemnation and disposal of item not authorized below depot level.
L	- Repairable item. Condemnation and disposal not authorized below specialized repair activity (SRA).
A	- Item requires special handling or condemnation procedures because of the specific reasons (e.g. precious metal content, high dollar value, critical material, or hazardous material). Refer to appropriate manuals/directives for specific instructions.

c. CAGEC (Column 3). The Commercial and Government Entity Code (CAGE) is a five digit numeric code which is used to identify the manufacturer, distributor, or Government agency, etc., that supplies the item.

d. PART NUMBER (Column 4). Indicates the primary number used by the manufacturer (individual, company, firm, corporation, or Government activity), which controls the design and characteristics of the item by means of its engineering drawings, specification standards, and inspection requirements to identify an item or range of items.

**NOTE**

When you use an NSN to requisition an item, the item you receive may have a different part number from the part ordered.

e. DESCRIPTION AND USABLE ON CODE (UOC) (Column 5). This column includes the following information:

- (1) The Federal item name and, when required a minimum description to identify the item.
  - (2) The physical security classification of the item is indicated by the parenthetical entry (insert applicable security classification abbreviation, e.g., Phy Sec C1 (C)-Confidential, Phy Sec C1 (S)-Secret, Phy Sec C1 M) -Top Secret.
  - (3) Items that are included in kits and sets are listed below the name of the kit or set.
  - (4) Spare/repair parts that make up an assembled item are listed below the name of the kit or set.
  - (5) Part numbers for bulk materials are referenced in this column in the line item entry for the item to be manufactured/fabricated.
  - (6) When the item is not used with all serial numbers of the same model, the effective serial numbers are shown on the last line(s) of the description (before UOC).
  - (7) The usable on code, when applicable, (see paragraph 5, Special information).
  - (8) In the Special Tools List section, the basis of issue (BOI) appears as the last line(s) in the entry for each special tool, special TMDE, and other special support equipment. When density of equipments supported exceeds density spread indicated in the basis of issue, the total authorization is increased proportionately.
  - (9) The statement, "END OF FIGURE" appears just below the last item description in Column 5 for a given figure in both Section II and Section III.
- f. QTY (Column 6). The QTY (quantity per figure column indicates the quantity of the item used in the breakout shown on the illustration figure, which is prepared for a functional group, subfunctional group, or an assembly. A "V" appearing in this column in lieu of a quantity indicates that a quantity is variable and the quantity may vary from application to application.

**4. Explanation of Columns (Section IV).**

a. NATIONAL STOCK NUMBER (NSN) INDEX.

(1) STOCK NUMBER column. This column lists the NSN by National Item identification number (NIIN) sequence. The NIIN consists of the last nine digits of the NSN, i.e.:

NSN  
5340-01-674-1467  
NIIN

When using this column to locate an item, ignore the first 4 digits of the NSN. However, the complete NSN should be used when ordering items by stock number.

(2) FIG Column. This column lists the number of the figure where the item is identified/located. The figures are in numerical order in Section II and Section III.

(3) ITEM Column. The item number identifies the item associated with the figure listed in the adjacent FIG. column. This item is also identified by the NSN listed on the same line.

b. PART NUMBER INDEX. Part numbers in this index are listed by part number in ascending alphanumeric J/sequence (i.e. vertical arrangement of letter and number combination which places the first letter or digit of each group in order A through Z, followed by the numbers 0 through 9 and each following letter or digit through like order).

(1) CAGEC Column. The Commercial and Government Entity Code (CAGEC) is a five-digit numeric code used to identify the manufacturer, distributor, or Government agency etc. that supplies the item.

(2) PART NUMBER Column. Indicates the primary number used by the manufacturer (individual, firm, corporation, or Government activity) which controls the design and characteristics of the item by means of its engineering drawing, specification standards, and inspection requirements to identify an item or range of items.

(3) STOCK NUMBER Column. This column lists the NSN for the associated part number and manufacturer identified in the PART NUMBER and FSCM columns to the left.

(4) FIG. Column. This column lists the number of the figure where the item is identified/located in Section II and Section III.

**5. Special Information.** Use the following subparagraphs as applicable:

a. USABLE ON CODE. The usable on code appears in the lower left corner of the Description column heading. Usable codes are shown as "UOC ..... "in the Description column (justified left) on the first line applicable to all models.

b. FABRICATION INSTRUCTIONS. Bulk materials required to manufacture items are listed in the Bulk Material Functional Group of this RPSTL. Part number for bulk materials are also referenced in the description column of the line entry for the item to be manufactured/fabricated. Detailed fabrication instructions for items source codes to be manufactured or fabricated are found in.

c. ASSEMBLY INSTRUCTION. Detailed assembly instructions for items source coded to be assembled from component spare/repair parts are found in. Items that make up the assembly are listed immediately following the assembly item or reference is made to an applicable figure.



d. KITS. Line item entries for repair kits appear in a group in Section II.

e. INDEX NUMBERS. Items which have the word BULK in the figure column will have an index number shown in the item number column. This index number is a cross reference between the National Stock Number/Part Number Index and the bulk material list in Section II.

f. ASSOCIATED PUBLICATIONS. The publication(s) listed below pertain to (insert applicable equipment nomenclature) and its components:

Publication	Short Title
N/A	

**NOTE**

Associated publications shall not be listed here in combines narrative and RPSTL manuals.

**6. How to Locate Repair Parts.**

a. When National Stock Number or Part Number is not known.

(1) First. Using the table of contents, determine the assembly group or subassembly group to which the item belongs. This is necessary since figures are prepared for assembly and subassembly groups, and listings are divided into the same groups.

(2) Second. Find the figure covering the assembly group or subassembly group to which the item belongs.

(3) Third. Identify the item on the figure and note the item number.

(4) Fourth. Refer to the Repair Parts List for the figure to find the part number for the item number noted on the figure.

(5) Fifth. Refer to the Part Number Index to find the NSN, if assigned.

b. When National Stock Number or Part Number is known:

(1) First. Using the Index of National Stock Numbers and Part Numbers, find the pertinent National Stock Number or Part Number. The NSN index is in National Item Identification Number (NIIN) sequence (see 4 a (1)). The part numbers in the Part Number index are listed in ascending alphanumeric sequence (see 4 b.). Both indexes cross reference you to the illustration figure and Item number of the item you are looking for.

(2) Second. After finding the figure and item number, verify that the item is the one you're looking for, then locate the item number in the repair parts list for the figure.

**THIS PAGE LEFT INTENTIONALLY BLANK**

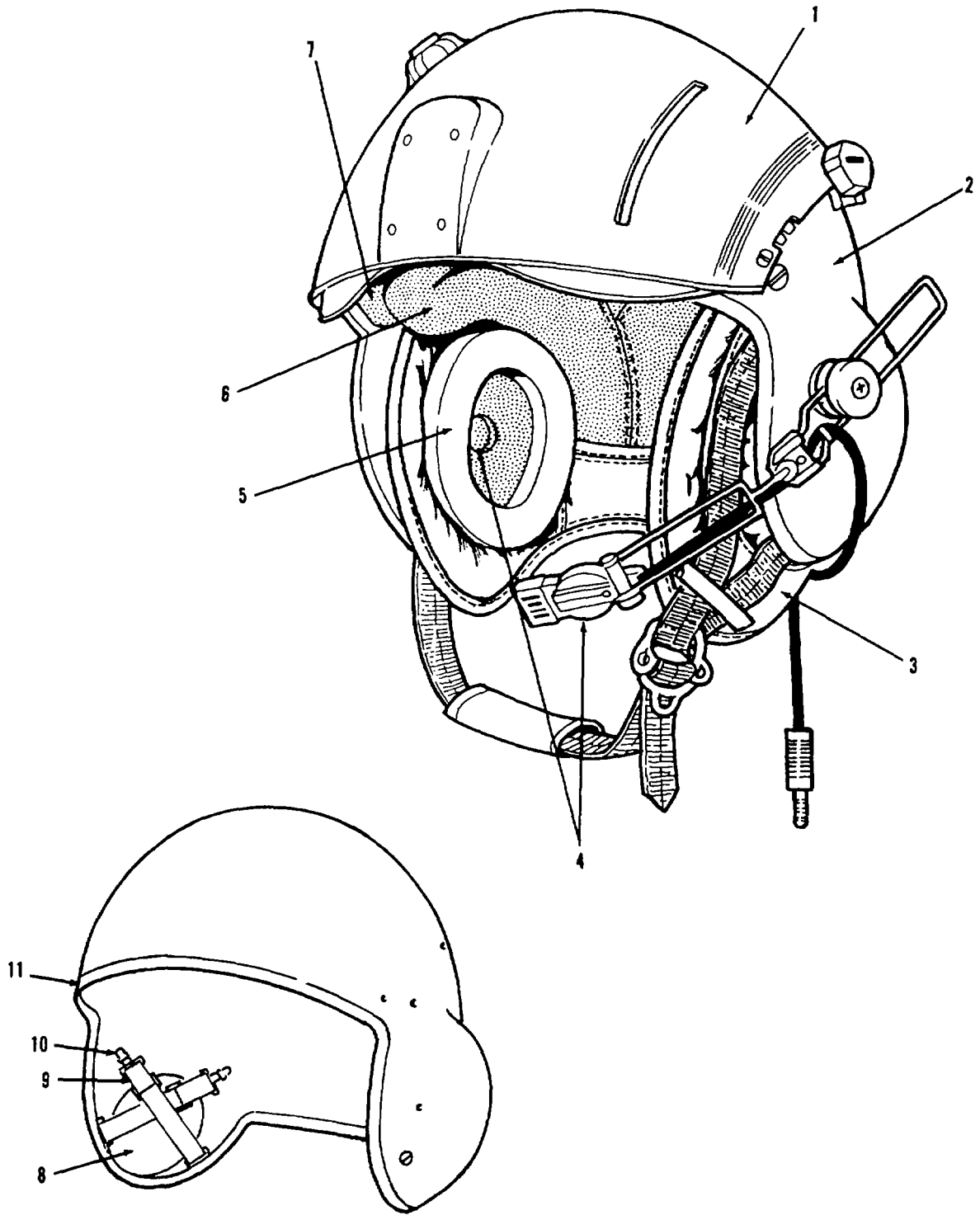

Figure C-1. SPH-4B Helmet Assembly

## Section II. REPAIR PARTS AND SPECIAL TOOLS LIST

## GROUP 01. HELMET ASSEMBLY

Figure C-1. SPH-4B Helmet Assembly

ITEM NO.	SMR CODE	CAGEC	PART NUMBER	DESCRIPTION AND USABLE ON CODE (UOC)	QTY
	PAOOO	97427	89D7825-1	HELMET ASSY, REGULAR	1
	PAOOO	97427	89D7825-2	HELMET ASSY, X-LARGE	1
1	PAOOO	97427	90C7930-12	.LIGHTWEIGHT DUAL VISOR ASSY (See fig. C-2 for breakdown)	1
2	PAOOO	97427	90A7858-1	.HELMET SHELL, REG.	1
2	PAOOO	97427	90AI858-2	.HELMET SHELL, X-LARGE	1
3	PAOOO	97427	89D7639-1	.RETENTION ASSY, 0. G. (See fig. C-4 for breakdown)	1
4	XAOZZ	97427	306A38	.COMMUNICATION ASSY (REF.)	1
5	PAOOO	97427	85C7136	.EAR CUP ASSY (See fig C-5 for breakdown)	2
6	PAOOO	97427	85D7087-4	.THERMOPLASTIC LINER ASSY, REG. (See fig. C-3 for breakdown)	1
6	PAOOO	97427	85D7087-5	.THERMOPLASTIC LINER ASSY, X-LARGE (See fig. C-3 for breakdown)	1
7	PAOOO	97427	85D7286-1	.LINER, ENERGY ABSORBING, REG. (See fig. C-3 for breakdown)	1
7	PAOOO	97427	85D7211-1	.LINER, ENERGY ABSORBING, X-LARGE (See fig. C-3 for breakdown)	1
8	PAOZZ	81337	8-2-827	.PAD, EAR CUP CHAFING	2
9	PAOZZ	81337	8-2-814	CROSS STRAP, EAR CUP TENSION	4
10	PAOZZ	81337	8-2-821	ADAPTER CLIP	4
11	PAOZZ	97427	63A1088	.EDGE, BEADING	1

END OF FIGURE

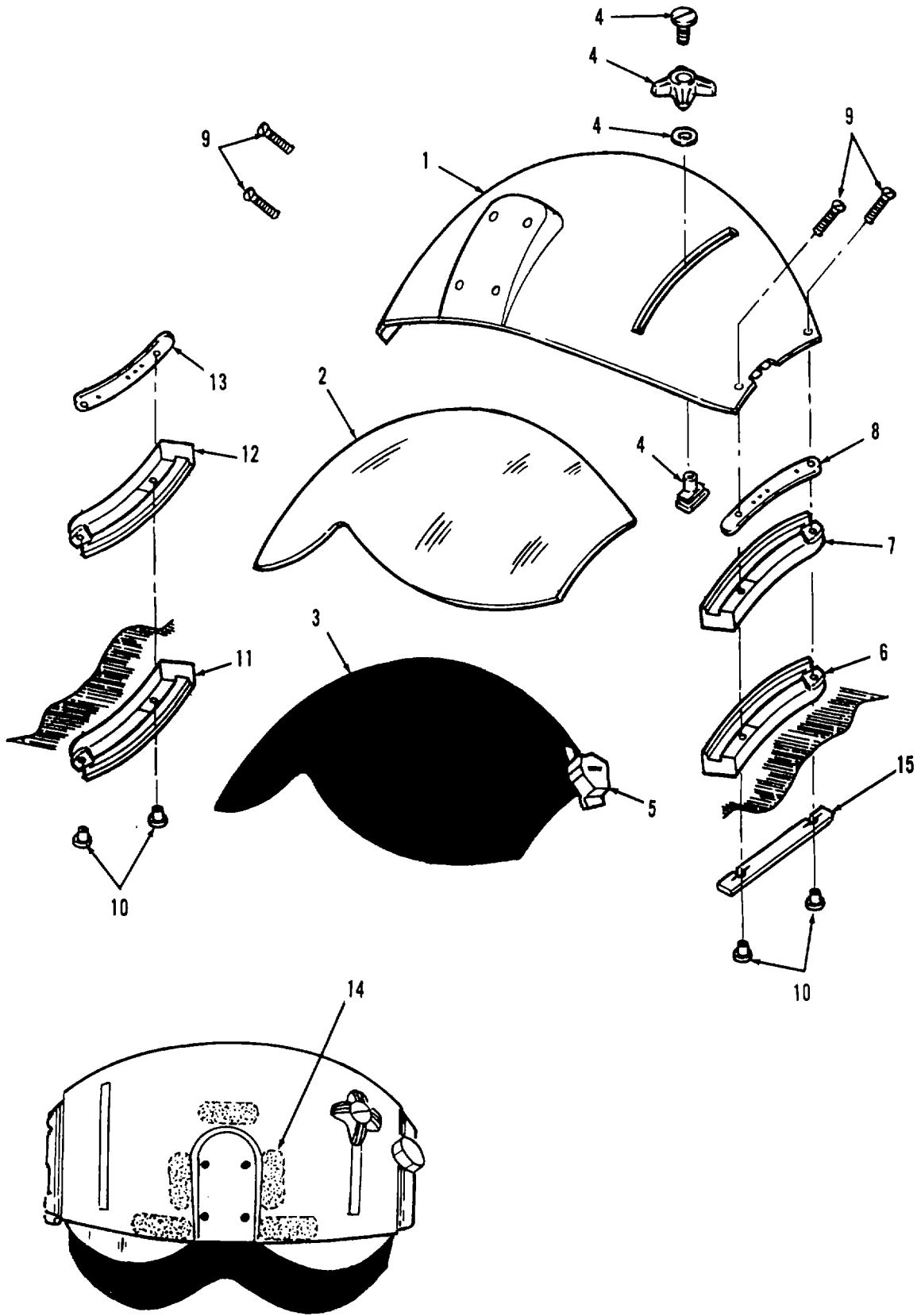

Figure C-2. Dual Visor Assembly

## GROUP 03. THERMOPLASTIC LINER ASSEMBLY

Figure C-3. Thermoplastic Liner Assembly

ITEM NO.	SMR CODE	CAGEC	PART NUMBER	DESCRIPTION AND USABLE ON CODE (UOC)	QTY
	PAOOO	97427	85D7087-4	THERMOPLASTIC LINER ASSY, REG (See fig C-1 for NHA)	REF
	PAOOO	97427	85D7087-5	THERMOPLASTIC LINER ASSY, X-LARGE (See fig C-1 for NHA)	REF
1	PAOZZ	97427	85C7257-4	LAYER ASSY, SML/REG	1
1	PAOZZ	97427	85C7257-1	.LAYER ASSY, REG	1
1	PAOZZ	97427	85C7257-2	.LAYER ASSY, X-LARGE	1
2	PAOZZ	97427	85D7088-11	.COVER, SMALL	1
2	PAOZZ	97427	85D7088-4	.COVER, REGULAR	1
2	PAOZZ	97427	85D7088-5	.COVER, X-LARGE	1
3	PAOZZ	97427	85D7286-1	.LINER, HELMET, REGULAR	1
3	PAOZZ	97427	85D7211-1	.LINER, HELMET	1
4	PAOZZ	97427	89A7826	.LINER PARTS, PACKAGE	1

END OF FIGURE

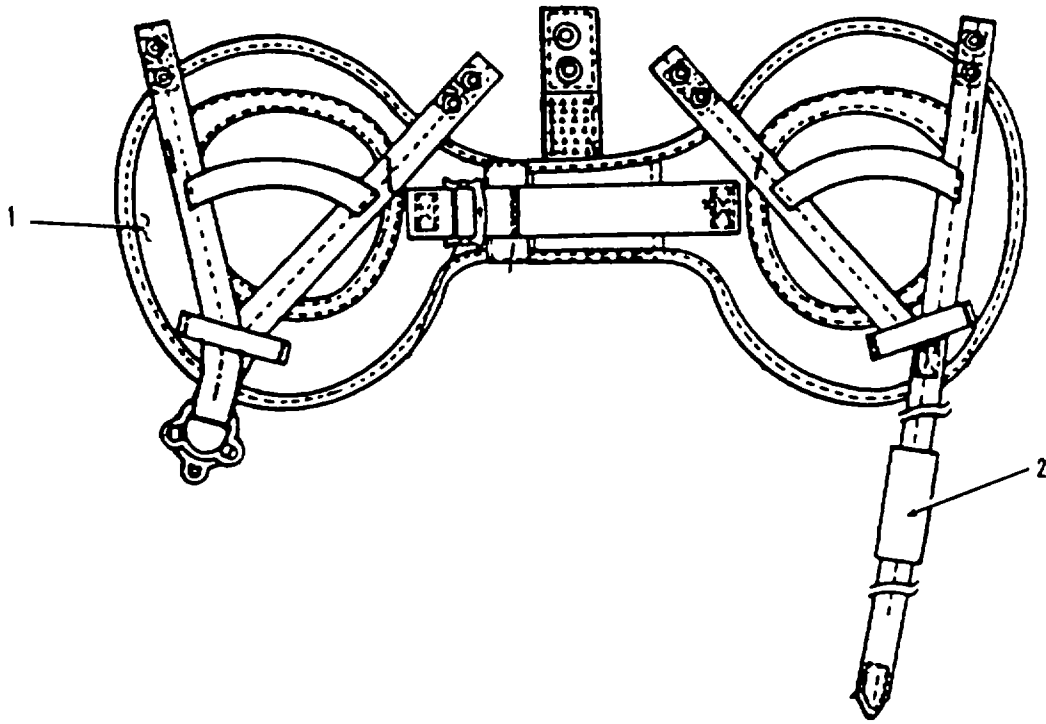

Figure C-4. Retention Assembly (Sheet 1 of 2)

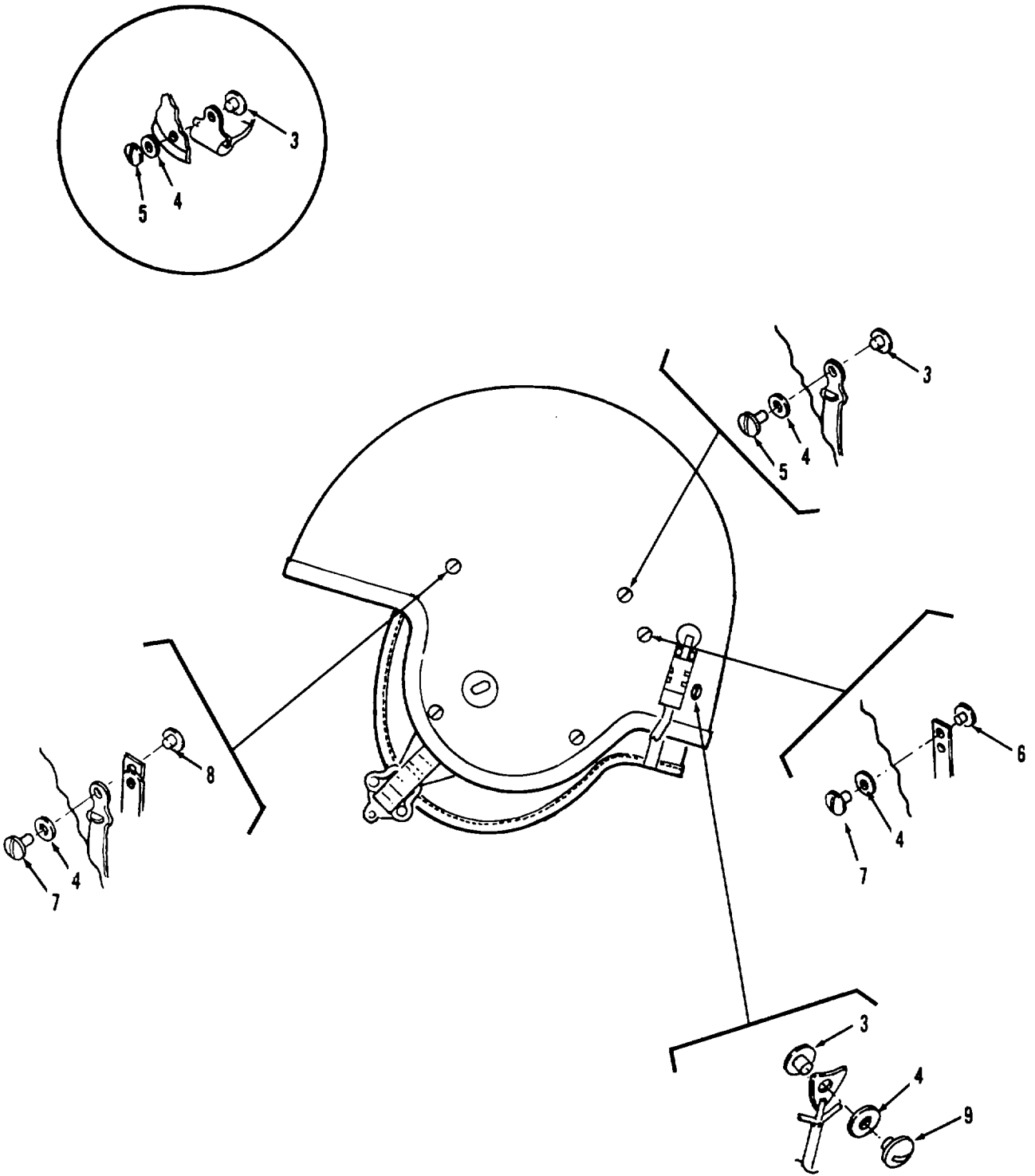

Figure C-4. Retention Assembly (Sheet 2 of 2)



## GROUP 04. RETENTION ASSEMBLY

Figure C4. Retention Assembly

ITEM NO.	SMR CODE	CAGEC	PART NUMBER	DESCRIPTION AND USABLE ON CODE (UOC)	QTY
1	PAOOO	97427	89D7639-3	RETENTION ASSY, O.G. (See fig C-1 for NHA)	REF
2	PAOZZ	97427	90C7952-1	.CHIN PAD, O.G.	1
3	PAOZZ	81337	8-2-818-3	.POST, 1/16 IN.	2
4	PAOZZ	97427	76A3443	.WASHER SPRING, CRES BLACK	2
5	XDOZZ	81337	8-2-820-1	.SCREW, 8-32 X 3/16 IN.	2
6	PAOZZ	97427	69A2104-2	.POST, 1/8 IN.	2
7	PAOZZ	97427	75A3093-9	.SCREW, 8-32 X 1/4 IN	5
8	PAOZZ	81337	8-2-818-1	.POST, 3/16 IN.	2
9	PAOZZ	97427	75A3093-2	.SCREW, 8-32 X 5/32 IN., BLACK	2

END OF FIGURE

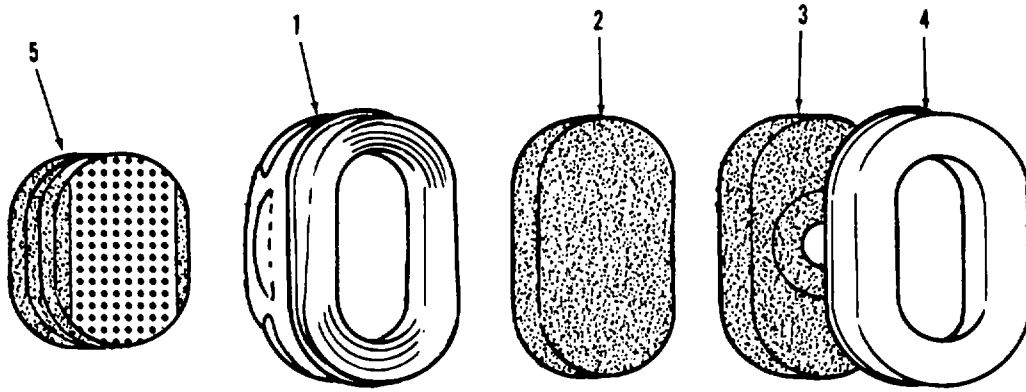

Figure C-5. Earcup Assembly

**GROUP 05. EARCUP ASSY KIT**

**Figure C-5. Earcup Assembly**

<b>ITEM NO.</b>	<b>SMR CODE</b>	<b>CAGEC</b>	<b>PART NUMBER</b>	<b>DESCRIPTION AND USABLE ON CODE (UOC)</b>	<b>QTY</b>
	PAOOO	97427	85C7136	EARCUP ASSY KIT (See fig. C-1 for NHA)	REF
1	PAOZZ	97427	85C7136-1	.EARCUP ASSY, L/H	1
1	PAOZZ	97427	85C7136-2	.EARCUP ASSY, R/H	1
2	PAOZZ	97427	83B6572-5	.CUSHION, BACKING	2
3	PAOZZ	97427	83C6573	.CUSHION, INSERT EARPHONE	2
4	PAOZZ	97427	75C2990-1	.EARPAD ASSEMBLY	2
5	PAOZZ	97427	71 B2302	.EARCUP SPACER KIT	1

END OF FIGURE

Section III. SPECIAL TOOLS LIST (NOT APPLICABLE)

Section IV. NATIONAL STOCK NUMBER AND PART NUMBER INDEX

NATIONAL STOCK NUMBER INDEX

STOCK NUMBER	FIGURE NO.	ITEM NO.	STOCK NUMBER	FIGURE NO.	ITEM NO.
8415-00-757-8212	C-1	11	8415-01-330-6609	C-1	3
8475-00-122-6659	C-1	9	8415-01-330-6609	C-4	1
5310-01-063-3044	C-4	4	8415-01-330-6610	C-2	1
5305-01-082-0017	C-2	9	8415-01-330-6611	C-1	2
5310-01-093-0914	C-4	3	8415-01-330-6612	C-1	2
5310-01-093-0915	C-4	8	8415-01-330-6613	C-2	6
5340-01-094-0523	C-4	6	8515-01-330-6614	C-2	7
5305-01-144-8908	C-4	7	8415-01-330-6615	C-2	11
8415-01-169-6436	C-1	10	8415-01-330-6616	C-2	12
8415-01-308-5359	C-1		8415-01-330-6617	C-5	4
8415-01-308-5360	C-1		8415-01-330-6618	C-5	3
8415-01-308-5361	C-1	1	8415-01-330-6619	C-5	2
8415-01-308-5361	C-2		8415-01-331-4234	C-1	8
8415-01-308-5362	C-5	1	5305-01-331-4369	C-4	9
8415-01-308-5363	C-3	2	5310-01-331-4516	C-2	10
8415-01-308-5364	C-3	2			
8415-01-308-5365	C-3	2			
8415-01-308-5366	C-1	7			
8415-01-308-5366	C-3	3			
8415-01-308-5367	C-1	7			
8415-01-308-5367	C-3	3			
8415-01-308-5368	C-3	4			
8415-01-308-8715	C-3	1			
8415-01-308-8716	C-3	1			
8415-01-308-8717	C-3	1			
8415-01-309-3433	C-5	1			
8415-01-330-6316	C-2	8			
8415-01-330-6317	C-2	13			
8415-01-330-6329	C-2	2			
8415-01-330-6330	C-2	3			

## PART NUMBER INDEX

CAGEC	PART NO.	FIG NO.	ITEM NO.	CAGEC	PART NO.	FIG NO.	ITEM NO.
97427	306A38	C-1	4	97427	85D7211-1	C-1	7
97427	63A1088	C-1	11	97427	85D7211-1	C-3	3
97427	69A2104-2	C-4	6	97427	85D7286-1	C-1	7
97427	71B2302	C-5	5	97427	85D7286-1	C-3	3
97427	75A3093-2	C-4	9	97427	89A7826-1	C-3	4
97427	75A3093-9	C-4	7	97427	89D7639-1	C-1	3
97427	75A3096-49	C-2	9	97427	89D7639-3	C-4	1
97427	75C2990-1	C-5	4	97427	89D7825-1	C-1	
97427	76A3443	C-4	4	97427	89D7825-2	C-1	
81337	8-2-523	C-2	4	97427	90A7858-1	C-1	2
81337	8-2-814	C-1	9	97427	90A7858-2	C-1	2
81337	8-2-817	C-2	10	97427	90C7930-12	C-1	1
81337	8-2-818	C-4	3	97427	90C7930-12	C-2	
81337	8-2-818	C-4	8	97427	90C7935-1	C-2	7
81337	8-2-820-1	C-4	5	97427	90C7935-2	C-2	
81337	8-2-821	C-1	10	97427	90C7952-1	C-4	2
81337	8-2-827	C-1	8	97427	90C8029-1	C-2	8
97427	82A5653-1	C-2	14	97427	90C8029-2	C-2	13
97427	83B6572-5	C-5	2	97427	90D7931-12	C-2	1
97427	83C6573	C-5	3	97427	90D7932-2	C-2	2
97427	85C7136	C-1	5	97427	90D7933-3	C-2	3
97427	85C7136	C-5		97427	90D7934-1	C-2	6
97427	85C7136-1	C-5	1	97427	90D7934-2	C-2	11
97427	85C7136-2	C-5	1	97427	91B8089-10	C-2	5
97427	85C7257-1	C-3	1				
97427	85C7257-2	C-3	1				
97427	85C7257-4	C-3	1				
97427	85D7087-4	C-1	6				
97427	85D7087-4	C-3					
97427	85D7087-5	C-1	6				
97427	85D7087-5	C-3					
97427	85D7088-11	C-3	2				
97427	85D7088-4	C-3	2				
97427	85D7088-5	C-3	2				

## APPENDIX D

EXPENDABLE SUPPLIES AND MATERIALS LIST

---

## Section I. INTRODUCTION

**D-1. Scope.** This appendix lists expendable materials and supplies you will need to operate and maintain the helmet. These items are authorized to you by CTA 50-970, Expendable Items (Except Medical, Class V, Repair Parts, and Heraldic Items).

**D-2. Explanation of Columns.**

a. Column (1)-Item number. This number is assigned to the entry in the listing and is referenced in the narrative instructions to identify the material (e.g., "Use cleaning compound, item 5, App. D").

b. Column (2)-Level. This column identifies the lowest level of maintenance that requires the listed item.

C - Operator

O - Organizational Maintenance

c. Column (3)-National Stock Number. This is the National stock number assigned to the item; use it to request or requisition the item.

d. Column (4)-Description. Indicates the Federal item name and, if required, a description to identify the item. The last line for each item indicates the Federal Supply Code for Manufacturer (FSCM) in parentheses followed by the part number.

e. Column (5)-Indicates the measure used in performing the actual maintenance function. This measure is expressed by a two-character abbreviation (e.g., ea, in, pr). If the unit of measure differs from the unit of issue, requisition the lowest unit of issue that will satisfy your requirements.

Section II. EXPENDABLE SUPPLIES AND MATERIALS LIST

(1) ITEM NUMBER	(2) LEVEL	(3) NATIONAL STOCK NUMBER	(4) DESCRIPTION	(5) U/M
1	O	8010-01-055-2319	Polyurethane O.D. Paint	Gal
2	O	8010-01-146-2650	Polyurethane O.D. Paint	Qt
3	O	8040-00-273-8717	Adhesive	Pt
4	O	8040-00-832-6173	Adhesive, Synthetic Rubber	Oz
5	O	8315-00-106-5973	Fastener Tape, Hook O.D. 1"	Ft
6	O	8315-00-106-5974	Fastener Tape, Pile O.D. 1 "	Ft
7	O	8315-00-498-6631	Fastener Tape, Pile O.D. 2"	Ft
8	O	7510-00-634-1549	Tape, Double-Sided, Pressure Sensitive Adhesive, P/N U-T-91 (81348)	RL

ALPHABETICAL INDEX

SUBJECT	PAGE NO.
<b>A</b>	
ANVIS Goggles (Attachment).....	3-33
ANVIS Mount Installation .....	3-32
AVUM PMCS .....	3-3
AVUM Troubleshooting .....	3-5
<b>C</b>	
Chafing Pad.....	3-35
Cleaning.....	3-10
Communications Cord .....	3-24
Components, Major, Location and Description .....	1-3
Controls, Description and Use.....	2-1
Cross Straps.....	3-34
<b>D</b>	
Differences Between Models.....	1-6
Donning/Doffing Helmet.....	2-4
Dual Visor Assembly .....	3-26
<b>E</b>	
Earcup Spacer Pads.....	3-22
Earcup and Earphones.....	3-18
Edge Beading.....	3-36
Energy-Absorbing Liner .....	3-12
Equipment Characteristics, Capabilities and Features .....	1-1
Expendable Supplies and Materials List.....	D-1
<b>F</b>	
Fitting Procedures .....	3-2
<b>H</b>	
Helmet Sizing and Fitting .....	3-1
<b>I</b>	
Inner Visor Knob .....	3-31



ALPHABETICAL INDEX (CONT)

SUBJECT	PAGE NO.
<b>M</b>	
Microphone/Boom/Swivel Assembly .....	3-23
<b>O</b>	
Operation of Standard Components.....	2-5
Operation Under Usual Conditions.....	2-4
Operators PMCS .....	2-9
Operator's Troubleshooting .....	2-13
Outer Visor Lock .....	3-30
<b>P</b>	
Paint ing.....	3-37
<b>R</b>	
Raising/Lowering Visors .....	2-7
Repair Parts .....	C-1
Retention Assembly .....	3-15
<b>S</b>	
Spacer Pad Applications.....	2-8
Strap Adjustment .....	2-6
<b>T</b>	
Thermoplastic Liner (TPL) .....	3-12, 3-13, 3-14
Trimming Hangar Tab .....	3-17

By Order of the Secretary of the Army:

GORDON R. SULLIVAN  
*General, United States Army*  
*Chief of Staff*

Official:

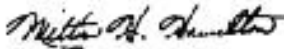

MILTON H. HAMILTON  
*Administrative Assistant to the*  
*Secretary of the Army*  
03343

DISTRIBUTION:

To be distributed in accordance with DA Form 12-31-E, block no. 3317, requirements for TM 1841521512&P.

RECOMMENDED CHANGES TO EQUIPMENT TECHNICAL PUBLICATIONS

 <div style="border: 1px solid black; border-radius: 15px; padding: 5px; display: inline-block; margin-left: 20px;"> <p style="margin: 0;"><i>THEN...JOT DOWN THE DOPE ABOUT IT ON THIS FORM. CAREFULLY TEAR IT OUT, FOLD IT AND DROP IT IN THE MAIL.</i></p> </div>		SOMETHING WRONG WITH PUBLICATION		
		FROM: (PRINT YOUR UNIT'S COMPLETE ADDRESS)		
PUBLICATION NUMBER		DATE SENT		
PUBLICATION DATE		PUBLICATION TITLE		
BE EXACT PIN-POINT WHERE IT IS				
PAGE NO.	PARA- GRAPH	FIGURE NO.	TABLE NO.	<p style="font-weight: bold; font-size: 1.1em;">IN THIS SPACE, TELL WHAT IS WRONG AND WHAT SHOULD BE DONE ABOUT IT.</p>
PRINTED NAME, GRADE OR TITLE AND TELEPHONE NUMBER			SIGN HERE	

## The Metric System and Equivalents

### *Linear Measure*

1 centimeter = 10 millimeters = .39 inch  
 1 decimeter = 10 centimeters = 3.94 inches  
 1 meter = 10 decimeters = 39.37 inches  
 1 dekameter = 10 meters = 32.8 feet  
 1 hectometer = 10 dekameters = 328.08 feet  
 1 kilometer = 10 hectometers = 3,280.8 feet

### *Weights*

1 centigram = 10 milligrams = .15 grain  
 1 decigram = 10 centigrams = 1.54 grains  
 1 gram = 10 decigrams = .035 ounce  
 1 decagram = 10 grams = .35 ounce  
 acres  
 1 hectogram = 10 decagrams = 3.52 ounces  
 1 kilogram = 10 hectograms = 2.2 pounds  
 1 quintal = 100 kilograms = 220.46 pounds  
 1 metric ton = 10 quintals = 1.1 short tons

### *Liquid Measure*

1 centiliter = 10 milliliters = .34 fl. ounce  
 1 deciliter = 10 centiliters = 3.38 fl. ounces  
 1 liter = 10 deciliters = 33.81 fl. ounces  
 1 dekaliter = 10 liters = 2.64 gallons  
 1 hectoliter = 10 dekaliters = 26.42 gallons  
 1 kiloliter = 10 hectoliters = 264.18 gallons

### *Square Measure*

1 sq. centimeter = 100 sq. millimeters = .155 sq. inch  
 1 sq. decimeter = 100 sq. centimeters = 15.5 sq. inches  
 1 sq. meter (centare) = 100 sq. decimeters = 10.76 sq. feet  
 1 sq. dekameter (are) = 100 sq. meters = 1,076.4 sq. feet  
 1 sq. hectometer (hectare) = 100 sq. dekameters = 2.47  
 1 sq. kilometer = 100 sq. hectometers = .386 sq. mile

### *Cubic Measure*

1 cu. centimeter = 1000 cu. millimeters = .06 cu. inch  
 1 cu. decimeter = 1000 cu. centimeters = 61.02 cu. inches  
 1 cu. meter = 1000 cu. decimeters = 35.31 cu. feet

### Approximate Conversion Factors

<i>To change</i>	<i>To</i>	<i>Multiply by</i>	<i>To change</i>	<i>To</i>	<i>Multiply by</i>
inches	centimeters	2.540	ounce-inches	Newton-meters	.007062
feet	meters	.305	centimeters	inches	.394
yards	meters	.914	meters	feet	3.280
miles	kilometers	1.609	meters	yards	1.094
square inches	square centimeters	6.451	kilometers	miles	.621
square feet	square meters	.093	square centimeters	square inches	.155
square yards	square meters	.836	square meters	square feet	10.764
square miles	square kilometers	2.590	square meters	square yards	1.196
acres	square hectometers	.405	square kilometers	square miles	.386
cubic feet	cubic meters	.028	square hectometers	acres	2.471
cubic yards	cubic meters	.765	cubic meters	cubic feet	35.315
fluid ounces	milliliters	29.573	cubic meters	cubic yards	1.308
pints	liters	.473	milliliters	fluid ounces	.034
quarts	liters	.946	liters	pints	2.113
gallons	liters	3.785	liters	quarts	1.057
ounces	grams	28.349	liters	gallons	.264
pounds	kilograms	.454	grams	ounces	.035
short tons	metric tons	.907	kilograms	pounds	2.205
pound-feet	Newton-meters	1.356	metric tons	short tons	1.102
pound-inches	Newton-meters	.11296			

### Temperature (Exact)

°F	Fahrenheit	5/9 (after	Celsius	°C
	temperature	subtracting 32)	temperature	

**PIN: 070881-002**